

**Global Fire Resistance Assessment
of:**

**Warm Springs Composite Products
60, 90 & 120 Minute
Fire Resisting Doorsets**

Report No;
Chilt/A06218 Revision F

Job Reference;
WF435276

Issue date: 19th November 2020

Valid until: 19th November 2021

Prepared for:

**Warm Springs Composite Products
Ltd.**
PO Box 906,
Warm Springs,
Oregon 97761,
USA

Contents

	Page No.
1 Introduction.....	3
2 General Description of Construction	4
3 Leaf Sizes.....	6
4 Doorset Configurations & Orientation.....	6
5 Leaf Size Adjustment	6
6 Overpanels and Side Panels.....	7
7 Glazing	9
8 Door Frames	13
9 Edging Materials.....	16
10 Leaf Facing Materials	16
11 Intumescent Materials	19
12 Adhesives	21
13 Tested Hardware.....	22
14 Additional & Alternative Hardware.....	23
15 Door Gaps	26
16 Structural Opening	26
17 Fixings	26
18 Sealing to Structural Opening	27
19 Insulation	28
20 Smoke Control.....	28
21 Conclusion.....	29
22 Declaration by the Applicant.....	30
23 Limitations	31
24 Validity.....	32
Appendix A - Performance Data	33
Appendix B - Tested Glazing System	35
Appendix C - Tectonite Door Frame Options	36
Appendix D - Revisions	38
Appendix E - Datasheets	39

1 Introduction

This document constitutes a global assessment relating to Warm Springs Composite Product (WSCP) doorsets, for Warm Springs Composite Product Ltd. The assessment uses established extrapolation and interpretation techniques in order to extend the scope of application by determining the limits for the design based on the tested constructions and performances obtained. The assessment is an evaluation of the potential fire resistance performance, if the elements were to be tested in accordance with BS 476: Part 22: 1987.

Much of the guidance that supports fire safety legislation in the UK is given in terms of performance in relation to British or European Standards which may take the form of test methods or agreed product standards.

Typically therefore a material, product or structure should:

- a) have a specification or design which has been shown by test to be capable of meeting the required performance; or
- b) have been assessed from test evidence generated against appropriate standards, or by using relevant design guides, to be capable of meeting the required performance.

This approach is outlined as being acceptable in paragraphs 1a) and 1b) of appendix A in Approved Document B Vol. 1 - Dwellinghouses (2019 edition) and Approved Document B Vol. 2 - Buildings other than dwellinghouses (2019 edition), the Passive Fire Protection Federation (PFPF) guide to undertaking technical assessments of the fire performance of construction products based on fire test evidence 2019 Industry Standard Procedure and.

Test reports provide information on the performance of a specimen that was tested against the relevant standard and do not offer any extension to scope (e.g. leaf dimensions or hardware options). Assessments are written based on applicable primary test evidence and extend the scope of application of the tested design to provide for different design options and are written by person(s) with the necessary expertise in the performance of construction products under fire test conditions, as detailed in appendix A of Approved Document B Vol. 1 and Vol. 2.

This assessment has been written to the principles outlined in the PFPF guidelines to undertaking assessments in lieu of fire tests. The aim of the PFPF guidelines is to give confidence to end-users that assessments that exist in the UK are of a satisfactory standard to be used in lieu of fire tests for building control and other purposes.

The PFPF guidelines are produced by the UK Fire Test Study Group (FTSG) an association of the major fire testing laboratories in the UK and are published by the PFPF, the representative body for the passive fire protection industry in the UK.

2 General Description of Construction

This WSCP door design comprises the following elements and is for 60, 90 and 120 minute fire resisting applications.

Element		Material	Dimensions (mm)		Density (kg/m ³)
Stiles		Tectonite	Minimum	25 (w) x 51 (t)	1000 +/- 10*
			Maximum	43 (w) x 51 (t)	
Rails (top and bottom)		Tectonite	Minimum	51 (w) x 51 (t)	1000 +/- 10*
			Maximum	102 (w) x 51 (t)	
Core		WSCP mineral core	51 (t)		288 +/-30*
Facings	Option 1	MDF	3 (t)		750**
	Option 2	HDF	3 (t)		820**
	Option 3	Plywood	3 (t)		640**
	Option 4	Chipboard	3 (t)		640**
Lippings		Hardwood	3 (t)		640*
Adhesive (facings, lippings, internal framing, core)		See section 12	-		-

*Stated by the client

**Nominal density

Minimum door thickness 56mm

2.1 Multi Piece Core, Stiles and Rails

2.1.1 Multi Piece Core

The testing conducted on the designs tested in CFR1007071, CFR1007081, CFR1009081 and CFR1103111 used door cores comprising multiple pieces (between 3 and 7). Tests CFR1009081 and CFR1007071 show that when a multipiece core is bonded together it behaves in a similar manner to a single piece core. It is therefore permitted to construct the door design using multiple pieces of core up to a maximum number of seven individual pieces glued together using cross linked PVA. Providing there are no gaps between them, the pieces may be rectangular or square of different dimensions to suit the door construction.

2.1.2 Multi Piece Stiles and Rails

The testing conducted on a sample of door leaf under WHI 495 PSV 1553 demonstrated that the Warm Springs design, when constructed with multi piece stiles and rails, was capable of providing a minimum of 90 minutes fire resistance when tested to the time temperature curve specified in UBC Standard 7-2 (1997): Fire tests of door assemblies. The door was further subjected to a hose stream that lasted 28 seconds.

Although the sample of door was subjected to an US test method, it can be used as suitable evidence to demonstrate that the WSCP door design can be constructed with multi piece Tectonite stiles and rails meeting the following specification, for 60 and 90 minutes fire resistance only:

1. Lengths of stile and rail must be no smaller than 400mm;
2. The sections of stile and rail must be glued together using cross linked PVA.

NB: 120 minute fire resisting designs must use continuous lengths of Tectonite for the stiles and rails; jointed sections are not permitted.

See section 8.1.1 for multi piece door frame requirements.

2.2 Banded Door Cores and Components

The door design can be supplied by Warm Springs Composite Products (WSCP) as Banded Door Cores (BDC) or as separate components to be constructed by the end user. In either case the door cores are to be constructed in strict accordance with the specification given in this global assessment for the relevant door design.

2.3 Enhanced Acoustic Performance

It is permitted to alter the construction of the design to provide for enhanced acoustic performance subject to the following provisos:

1. The outer facing may be increased to 6mm thick (MDF only);
2. Single leaf configurations only;
3. All leaf dimensions given in the data sheets contained in appendix E are permitted at 60 and 90 minutes fire resistance;
4. Maximum leaf dimensions of 2292mm (h) x 1068mm (w) are permitted at 120 minutes fire resistance;
5. Norsound NOR810s drop seal may be fitted in the bottom rail subject to the intumescent gasket remaining in the bottom of the leaf as specified in section 11 (intumescent seal will be partially interrupted by the fitting of the drop seal);
6. Norsound NOR710 may be fitted around the perimeter of the leaf providing the intumescent specification required in section 11 is not altered and intumescent strips are not interrupted by the seal;
7. All other details to remain as specified in this assessment.

3 Leaf Sizes

Assessment for increased leaf dimensions is based on the design's performance and the characteristics exhibited during test. Data sheets specifying the maximum assessed leaf sizes and graphs showing the permitted gradient between maximum height and width are contained in appendix E.

Unequal leaf double doorsets are covered by this assessment with no restriction on the smaller leaf dimension.

Doorsets containing leaves with smaller dimensions than those stated are deemed to be less onerous and are therefore automatically covered.

4 Doorset Configurations & Orientation

Based on the test evidence listed in appendix A, this assessment covers the following doorset configurations.

The primary fire resistance tests for these designs were all conducted with the doorset hung such that the door leaf opened towards the fire, which is considered the most onerous orientation in terms of fire resistance performance, given the known behaviour of the mineral core material in fire test conditions. Based on this testing, assessment is made that the fire risk may be from either side of the doorset.

4.1 60 Minutes Fire Resistance

Abbreviation	Description
LSASD & ULSASD	Latched & unlatched single acting single doorset
DASD	Double acting single doorset
LSADD & ULSADD	Latched & unlatched single acting double doorset
DADD	Double acting double doorset

4.2 90 & 120 Minutes Fire Resistance

Abbreviation	Description
LSASD & ULSASD	Latched & unlatched single acting single doorset
LSADD & ULSADD	Latched & unlatched single acting double doorset

5 Leaf Size Adjustment

WSCP door leaves may be altered as follows:

Element	Reduction
Leaf	The manufactured size of the leaf may be adjusted at any edge providing the stiles are not reduced below 25mm (w) and the rails are not reduced below 51mm (w) and the lipping is replaced in accordance with section 9.1
Lipping	The dimensions stated in section 9.1 may be reduced by 20% for fitting purposes

6 Overpanels and Side Panels

6.1 Overpanels

Overpanels of the same construction as the door leaves may be used with this doorset design only when a transom is fitted between the leaf head and overpanel.

The transom must be of the same section and material assessed for the door frames, mortice and tenon or butt jointed to the jambs (with no gaps), bonded with cross linked PVA or urea/resorcinol formaldehyde and fixed with a minimum of 3 nail or screw fixings penetrating by a minimum of 40mm (see section 8.1 for additional information on frame specification).

The overpanels must always be on the same plane as the doors below and must be fixed by screwing through the rear of the frame with coarsely threaded wood type, steel screws passing at least 40mm into the centre line of the overpanel. Fixings must be no more than 100mm from each corner and a maximum of 250mm centres in between.

The intumescent seals specified for the jambs in appendix E, must be fitted to all edges of the overpanel. The seals may be fitted in the overpanel edges or alternatively in the frame reveal.

The maximum assessed overpanel heights are as follows.

Configuration	Permitted Overpanel Height (mm)
Single Doorsets	500
Double Doorsets	500

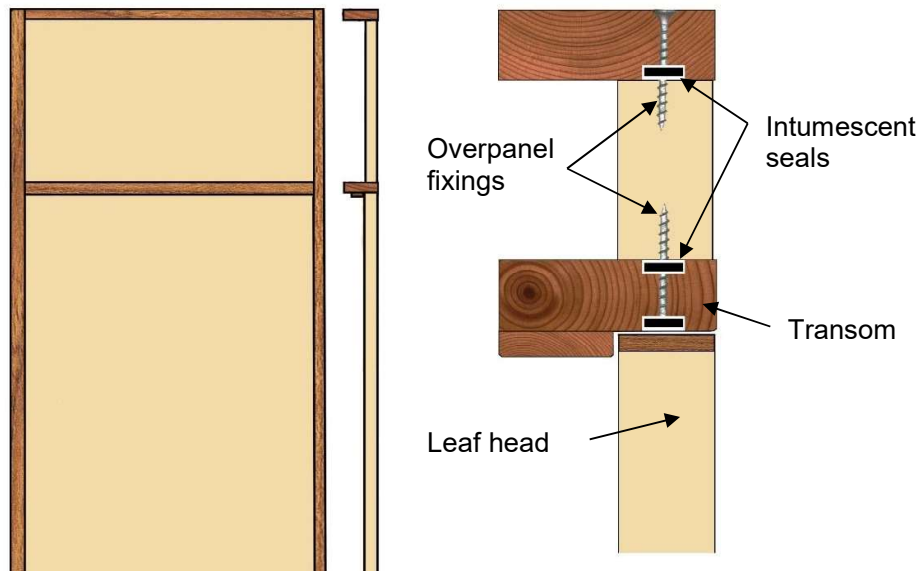

Note: Drawing is representative of doorset construction, actual construction must be as the text within this document specifies.

6.2 Side Panels

Side panels of the same construction as the door leaves may be used with this doorset design meeting the following specification:

1. Sidepanels may only be used with single leaf doorsets;
2. The swinging leaf must be hung from the door frame that is directly fixed back to the structural opening (i.e. it is not permitted to hang the leaf from the frame that separates the side panel from the leaf);
3. The maximum permitted dimensions of the side panel are for the height of the leaf and no more than 500mm in width;
4. The side panel must be located in the same plane as the door leaf;
5. The side panel may be used in conjunction with an overpanel providing the overpanel is located above the side panel, including a separating transom and the overall assembly is no wider than 1500mm in total;
6. The frame separating the side panel and door leaf must be of the same section and material assessed for the door frames, mortice and tenon or butt jointed to the frame head (with no gaps), bonded with cross linked PVA or urea/resorcinol formaldehyde and fixed with a minimum of 3 steel fixings penetrating by a minimum of 40mm (see section 8.1 for additional information on frame specification);
7. The side panel must be fixed by screwing through the rear of the frame with coarsely threaded wood type, steel screws passing at least 40mm into the centre line of the side panel. Fixings must be no more than 100mm from each corner and a maximum of 250mm centres in between;
8. The intumescent seals specified for the jambs in appendix E, must be fitted to all edges of the side panel. The seals may be fitted in the side panel edges or alternatively in the frame reveal.

7 Glazing

7.1 Option 1 (up to 120 minutes)

Test referenced Warres 63295 was conducted on a similar composite door construction to the WSCP design and was fitted with a Lorient Polyproducts Ltd. 120 minute glazing system.

Based on the equivalence of the door construction and the 24% margin of over run in performance achieved by the glazing system, we consider that the Lorient FD120 system can be used for glazing the WSCP doorset design.

The approved system is to be installed as follows.

Element	Make/Type	Size (mm)	Location
Glass Type	Firelite ceramic glass	5 thick	Fitted a minimum of 115mm from the leaf head and 115mm from the meeting/closing edge
Expansion Allowance	-	2-3 all edges	-
Beading	1.2 thick stainless steel (Z section)	25 over door face 11 return across reveal 22 upstand to glass	Fitted on both faces around the perimeter of the glazing aperture and mitred at the corners
Beading Fixings	Min. of 3No. bolts per length	M6 x length required to pass through leaf	Through cover bead face with a fixing no more than 75mm from each corner

Glazed openings must not be less than 115mm from any door edge. Multiple apertures are acceptable within the permitted glazed area, with a minimum dimension of 100mm between apertures. Aperture shape is restricted to square or rectangular up to a maximum assessed total glazed area of 0.18m².

A sectional drawing detailing the assessed glazing system is contained in appendix B.

7.2 Option 2 (up to 120 minutes)

Test referenced CFR1806192 was conducted on the WSCP design and was fitted with a Sealmaster Ltd, Fireglaze 2000 glazing system and achieved an integrity performance in excess of 120 minutes.

The approved system is to be installed as follows, and may be used in all door designs and configurations for up to 120 minutes performance.

Approved glass type: 10mm thick Pilkington Pyrodur EW60-10, expansion allowance 3mm on all edges

Glazing system: Dixon International Group Ltd GL60 liner, 54 wide x 2 mm thick fitted lining the glazed aperture, with Sealmaster Fireglaze 2000 25 high x 5mm thick (uncompressed) fitted between the glass and beads.

Beads: Glazing beads must be manufactured from hardwood of minimum density 770 kg/m³ (the use of Beech, *Fagus sylvatica*, is not permitted), meeting the dimensions shown below.

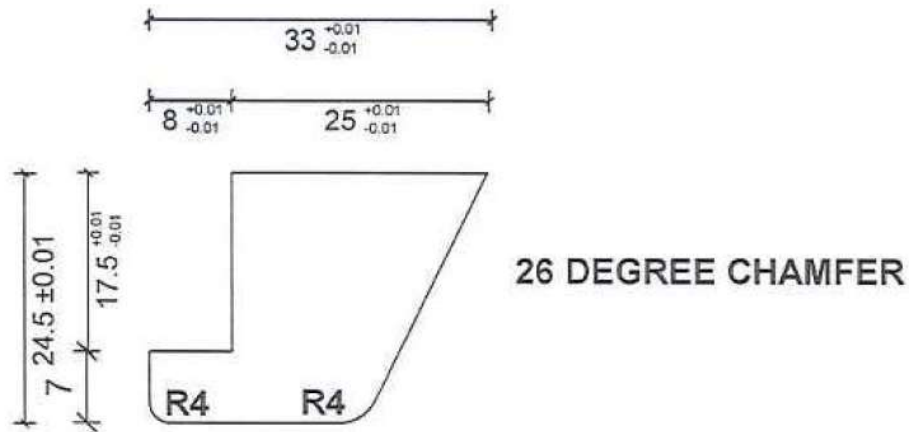

Bead fixings: The beads must be fixed into the 51mm (high) tectonite aperture liner using PVA adhesive and 74mm long x ø4.5 steel screws at no more than 50mm from any corner, at maximum 150mm nominal centres on the vertical edges and at maximum 75mm nominal centres on the horizontal edges. See diagram below.

Position: Glazed openings must not be less than 200mm from the top edge of the leaf and not less than 150mm from any vertical edge. Multiple apertures are acceptable within the permitted glazed area, with a minimum dimension of 150mm between apertures. Aperture shape is restricted to square or rectangular up to a maximum assessed total glazed area of 0.22m².

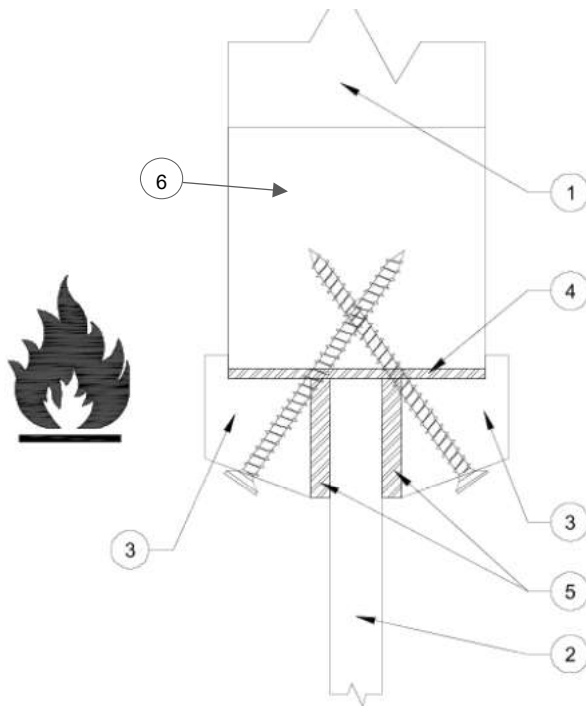

Key:

- 1. WSCP Core
- 2. Pyrodur EW60-10
- 3. Hardwood Beads
- 4. GL60 Liner
- 5. Fireglaze 2000
- 6. 51mm (h) Tectonite aperture framing

7.3 Option 3 (up to 90 minutes)

Test referenced Chilt/IF12047 was conducted on the WSCP design and was fitted with a Norsound Ltd, Norglaze Universal 90 glazing system.

Based on the over run in performance achieved by the glazing system, we consider that the Norglaze Universal 90 glazing system can be used for glazing the WSCP doorset design for up to 90 minutes fire resistance applications.

The approved system is to be installed as follows:

Approved glass type: 6mm thick Schott Pyran S, expansion allowance 3mm on all edges

Glazing system: Norglaze Universal 90 glazing system to be installed as per manufacturer's instructions. A face fix method and reveal fix method is available (see diagrams below)

Bead fixings: The beads must be fixed into the 20mm (t) tectonite aperture liner using PVA adhesive and 15mm long steel grub screws at 150mm nominal centres and no more than 50mm from any corner. See diagrams below for glazing options.

Glazed openings must not be less than 165mm from any door edge. Multiple apertures are acceptable within the permitted glazed area, with a minimum dimension of 100mm between apertures. Aperture shape is restricted to square or rectangular up to a maximum assessed total glazed area of 0.18m².

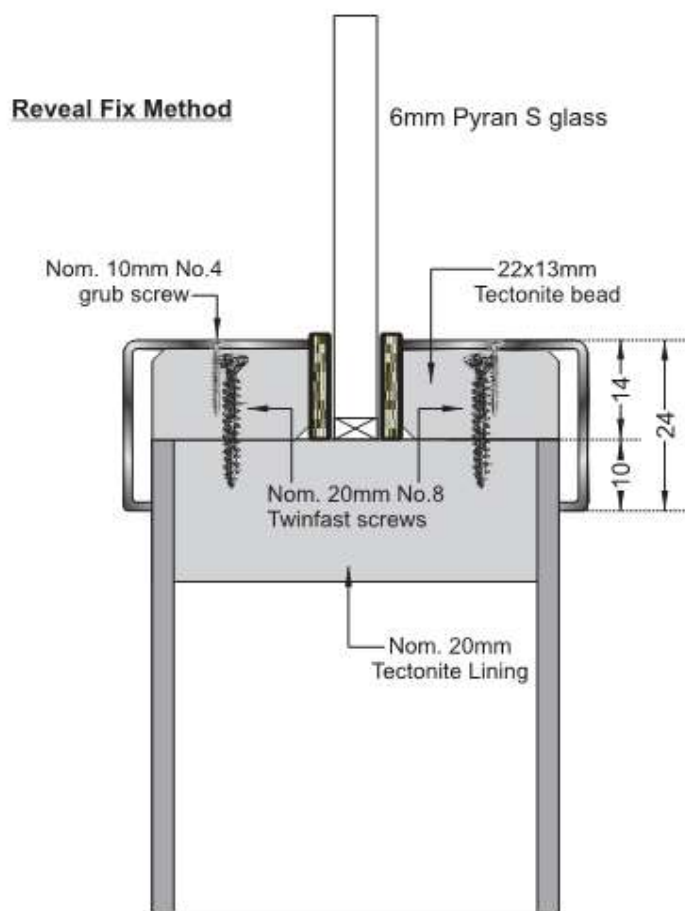

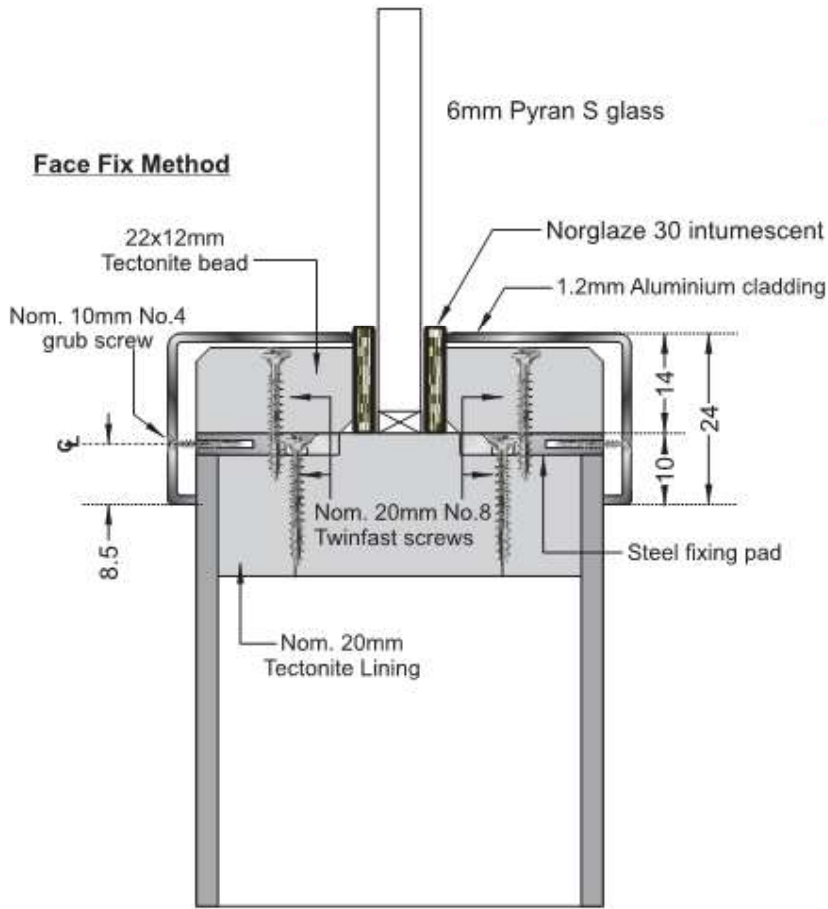

Fixing Pads

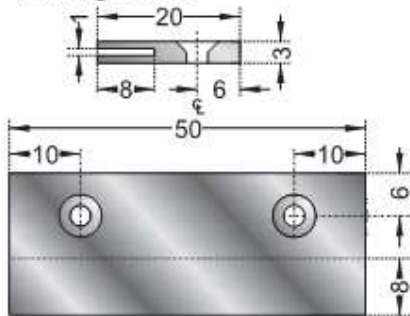

8 Door Frames

8.1 Door Frame Construction

Door frames for WSCP doorsets must meet the following specification.

Material	Min. Section (mm)	Min. Density (kg/m ³)	Leaf Configuration
Hardwood ¹ (60 & 90 minutes fire resistance only)	90(w) x 38(t) (excluding the stop)	680	Single and double
Tectonite (2mm or 4mm hardwood or MDF veneer)	94(w) x 43(t) (excluding the stop)	1000 +/- 10	Single and double
Tectonite (Hardwood composite)	112(w) x 47(t) (excluding the stop) Overall frame dimension see appendix C for construction	1000 +/- 10 (Tectonite) 680 (Hardwood)	Single and double

Notes:

- The use of Beech (*Fagus sylvatica*) is not permitted
- If the doorset features a transomed overpanel, the door frame must meet the following specification: Hardwood (680kg/m³) – 90(w) x 45(t) – Single and double leaf for 60 & 90 minutes fire resistance only;
- Tectonite (2 or 4mm hardwood veneer or hardwood composite) – Single and double leaf.
- All door frame timber must be to straight grained, joinery quality, free from knots , splits and checks
- A 12mm deep stop, planted or rebated from solid, is adequate for single acting frames. It is permitted to fix a planted stop through the rear of the frame using a suitable fixing for the frame material. The fixing must penetrate the stop to a depth of 8mm
- A planted stop may be hardwood or Tectonite meeting the specification in the table above for 60, 90 or 120 minutes fire resistance
- A T-Stop planted stop detail is acceptable and is depicted in appendix C
- Timber frame joints may be mitred, half lapped or butted and with no gaps. All jointing methods require mechanical fixing with the appropriate size ring shank nails or coarsely threaded wood type steel screws
- Tectonite frame joints must be butt jointed or mortice and tenoned with 3 No. coarsely threaded wood type steel screws per joint. The Tectonite must have pilot holes drilled in order to facilitate construction (and the fitting of hardware)
- It is possible to extend the width of the 94 (w) Tectonite frame by joining a section of hardwood using either a butt joint or tongue and grooved joint.

See appendix C for details on the two Tectonite door frame constructions.

8.1.1 Multi Piece Tectonite Frames

Based on the testing conducted on a sample of door leaf under WHI 495 PSV 1553 (see section 2.1.2 for discussion), it is permitted to construct door frame elements, both head and jambs, using multiple pieces of Tectonite, subject to the following requirements.

1. Lengths of frame must be no smaller than 400mm
2. Sections of frame must be glued together using cross linked PVA
3. Each section of Tectonite framing must be fixed to the supporting construction individually, in line with section 17. At least one fixing must be installed in every frame section piece, including in the frame head.

NB: 120 minute fire resisting designs must use continuous lengths of Tectonite for the head and jambs; jointed sections are not permitted.

8.2 Door Frame Profile

The following diagram depicts the assessed frame profiles and dimensions:

Hardwood Frame:

A = min 90mm B = min 38mm C = min 12mm

Tectonite Frame (2mm or 4mm hardwood or MDF veneer)

A = min 94mm B = min 43mm C = min 12mm

Tectonite Frame (Hardwood composite)

A = min 112mm B = min 47mm C = min 12mm

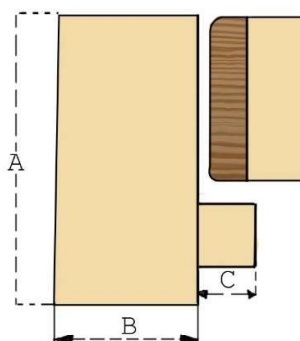

8.3 Door Frame Installation

The following diagram indicates the permitted type of door frame installation (see section 17 for suitable frame fixing details and section 18 for sealing to structural opening).

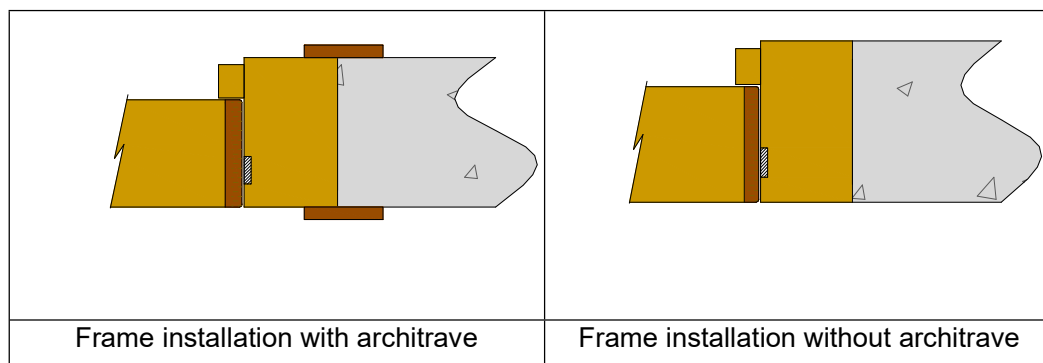

8.4 Door Frame Joints

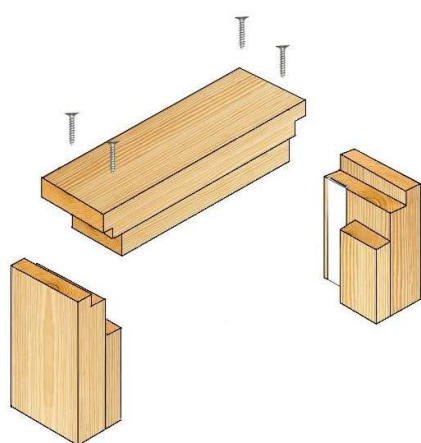

Half Lapped Joint

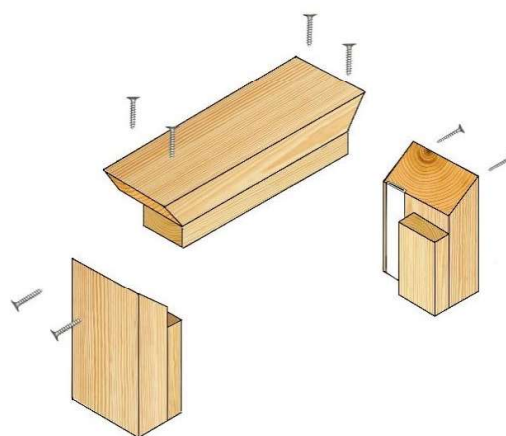

Mitre Joint

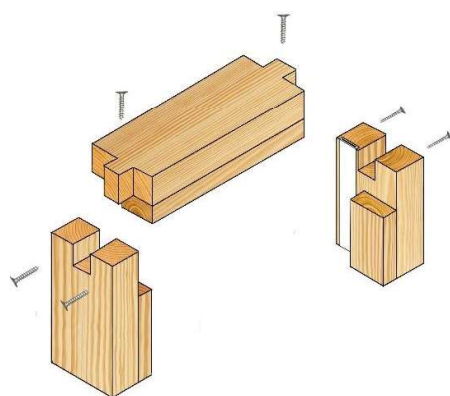

Mortice and Tenon Joint

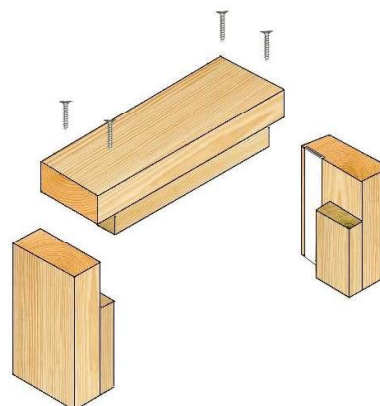

Butt Joint

Note: Drawing is representative of each type of door frame joint, actual construction in terms of intumescent seal location and material etc. must be as the text within this document specifies.

9 Edging Materials

9.1 Timber Lippings

The WSCP door design must be lipped in accordance with the following specification.

Material	Size (mm)	Min. Density (kg/m ³)
All timber for lipping must be joinery quality straight grained hardwood ¹ free from splits, checks and knots	Flat = 4 thick with a maximum of 2mm profiling permitted at corners of lipping	640

Notes:

1. The use of Beech (*Fagus sylvatica*) is not permitted
2. Rebated leaf edges are not permitted
3. Door leaves must be lipped on the vertical edges but may be lipped on all edges if required.

10 Leaf Facing Materials

10.1 General

Based on the type and thickness of the external facing materials tested for the WSCP Design, the following facing materials are approved.

Material	Thickness (mm)	Min. Density (kg/m ³)
MDF	3 – 4 (6mm is permitted for acoustic applications – see section 2.3)	750
HDF	3 - 4	820
Plywood	3 - 4	680
Chipboard	3 - 4	640

10.2 Decorative and Protective Facings

The following additional facing materials are permitted for this door design since they would degrade rapidly under test conditions without significant effect.

Facing Material	Maximum Permitted Thickness (mm)
Paint	0.5
Timber veneers	2
PVC/Plastic laminates	2
Cellulosic & non-metallic foil	0.5

Notes:

1. Metallic facings are not permitted, except for push plates and kick plates;
2. The door leaf thickness may be reduced by a total maximum of 0.5mm for calibration purposes in order to accommodate the chosen finish;
3. Materials must not conceal exposed intumescent strips;
4. PVC/plastic laminates must not be applied to the edges of leaves.

10.3 Decorative Grooves

The outer facing has been deemed as having negligible influence on the structural stability of the door design. It is therefore permitted to groove/recess both faces of the door leaf with any decorative pattern subject to the following provisos:

1. The amount of material removed from any one face must not exceed 30%;
2. The depth of the groove/recess must not exceed 3mm;
3. The groove/recess may run to the leaf edge;
4. The groove/recess must not coincide with any glazed apertures i.e. the groove or recess must stop short of the beading system for the glass.

The following picture provides an example of the type of pattern this groove/recess option would permit:



10.4 Decorative Grooves with Aluminium Inserts

The WSCP door design may be grooved to the following specification and fitted with an aluminium insert.

Element	Details	
Max. groove size (mm)	10 wide x 4 deep	
Proximity to door edges (mm)	Horizontal grooves	≥ 150 from top and bottom
	Vertical grooves	≥ 150 from sides
Groove spacing (mm)	≥ 150	
Orientation	Vertical or horizontal	
Configuration	Latched and unlatched, single acting, single and double doorsets	
Leaf size range (mm)	All	

Notes:

1. The grooves must not coincide with any glazed apertures;
2. A maximum of 4 No. vertical and 4 No. horizontal grooves are permitted perpendicular and intersecting one another providing all other details meet the specification given in the table above;
3. The grooves may run to the leaf edges;
4. To accommodate the aluminium insert the outer facing for the WSCP door design must be increased to a minimum of 5mm thick. The groove may be a maximum of 4mm deep and all other details must remain as detailed in the table above.

11 Intumescent Materials

11.1 General

The seal specification for each configuration is shown in appendix E.

The intumescent materials tested and assessed for the WSCP doorset design are as follows.

11.2 Intumescent Option 1

Application		Make/Type	Size (mm)	Location	
Leaf edges	Head	None fitted	-	-	
	Hanging edges	None fitted	-	-	
	Meeting edges	Left leaf	Intumescent Seals – WSCP PVC-seal	22 x 4	Set within a groove 5mm from the opening face
		Right leaf	Intumescent Seals – WSCP PVC-seal	22 x 4	Set within a groove 5mm from the closing face
	Bottom of leaf	Intumescent Seals – WSCP Flex-seal (uncased graphite)	47 x 1	Fitted centrally in a groove in the leaf and over sailing the lippings	
Frame reveal	Head	Intumescent Seals – WSCP PVC-seal	22 x 4	Set within a groove 7mm from the opening face	
			22 x 4	Set within a groove 33 from the opening face	
	Jambs	Intumescent Seals – WSCP PVC-seal	22 x 4	Set within a groove 7mm from the exposed face	
			22 x 4	Set within a groove 33 from the opening face	
Under hinge blade		Intumescent Seals – WSCP Strip-seal	2 thick	Under both hinge blades of all hinges	
Encasing latch body (120 minute applications only)		Intumescent Seals – WSCP Strip-seal	1 thick	Wrapped around lock case	
Under latch forend		Intumescent Seals – WSCP Flex-seal	1 thick	Fitted under latch forend	
Under latch strike		Intumescent Seals – WSCP Flex-seal	1 thick	Fitted under latch strike (also at base of latch and lock rebates in frame)	

Notes:

1. The intumescent specification is permitted for 30, 60 and 120 minutes fire resistance integrity performance;

11.3 Intumescent Option 2

Application		Make/Type	Size (mm)	Location	
Leaf edges	Head	None fitted	-	-	
	Hanging edges		None fitted	-	
	Meeting edges	Left leaf	Intumescent Seals – WSCP PVC-seal	20 x 4	Set within a groove 5mm from the opening face
		Right leaf	Intumescent Seals – WSCP PVC-seal	20 x 4	Set within a groove 5mm from the closing face
	Bottom of leaf		Intumescent Seals – WSCP Flex-seal (uncased graphite)	47 x 1	Fitted centrally in a groove in the leaf and over sailing the lippings
Frame reveal	Head	Intumescent Seals – WSCP PVC-seal	20 x 4	Set within a groove 7mm from the opening face	
			25 x 4	Set within a groove 33 from the opening face	
	Jambs	Intumescent Seals – WSCP PVC-seal	20 x 4	Set within a groove 7mm from the opening face	
			25 x 4	Set within a groove 33 from the opening face	
Under hinge blade		Intumescent Seals – WSCP Strip-seal	2 thick	Under both hinge blades of all hinges	
Encasing latch body (120 minute applications only)		Intumescent Seals – WSCP Strip-seal	1 thick	Wrapped around lock case	
Under latch forend		Intumescent Seals – WSCP Flex-seal	1 thick	Fitted under latch forend	
Under latch strike		Intumescent Seals – WSCP Flex-seal	1 thick	Fitted under latch strike (also at base of latch and lock rebates in frame)	

Notes:

1. The intumescent specification is permitted for 30, 60 and 120 minutes fire resistance integrity performance;

12 Adhesives

The following adhesives must be used in construction of the WSCP door design.

Element	Product/Manufacturer
Facings	Cross linked PVA
Lipping	Cross linked PVA or Hotmelt adhesive
Internal framing (stiles and rails)	Cross linked PVA
Core (bonded to perimeter framework)	Cross linked PVA

12.1 Facings

The following information is given in relation to gluing the facings for the WSCP door design:

1. The adhesive spread rate recommendation for the facings is 250-350g/m²;
2. The adhesive must be applied directly to the facing material and not the mineral core due to the porosity and absorption rate of the mineral core and for controlling the spread rate being used (as listed above).

13 Tested Hardware

The following hardware has been successfully incorporated in the tests on the WSCP doorset design.

Element	Make/Type	Size (mm)	Location
Hinges	Royde & Tucker Hi load 207 lift-off type	100 x 30 (blade size)	Fitted 198, 398 and 1798 from the head of the leaf
	Royde & Tucker Hi load H105 lift- off type	98 x 22 (blade size)	Fitted 150, 771, 1392 and 2013 from the head of the leaf
Closers	Dorma Door Controls Ltd. TS83V overhead type	293 x 60 (footprint size)	Fitted to the exposed face of each leaf as per the manufacturer's instructions
	Briton 2003SES	250 x 47 (footprint size)	Fitted to the exposed face of each leaf as per the manufacturer's instructions
Latches/Locks	5 lever Legge lock/latch	154 x 22 (forend size)	Fitted 1180 from the head of the leaf to the centre of the nib
	Dormer 752F sash lock and Dale NP30/10/30 double cylinder 7200	235 x 20 (Forend size)	Centreline of forend at 1000 above leaf bottom
	Dale 97170 Tubular mortise latch	57 x 25 (Forend size)	Centreline of forend at 1000 above leaf bottom
	Aluminium lever handle	102 x 40 (back plate)	Fitted to suit the latch position
	Necked barrel bolt (code 5528)	76 x 25 (back plate)	Fitted to the inactive leaf of double doorset 50 from meeting stile on the closing face and engaged

14 Additional & Alternative Hardware

The following sections detail the permitted scope and constraints for fitting hardware to these door designs.

14.1 CE Marking

The following items of hardware must also bear the CE Mark:

- Latches & Locks: Test Standard EN 12209
- Single Axis Hinges: Test Standard EN 1935
- Controlled Door Closing Devices: Test Standard EN 1154
- Panic Exit Hardware: Test Standard EN 1125
- Door Co-ordinators: Test Standard EN 1158.

14.2 Certifire

Providing the parameters of this assessment always take precedence, including specified protection such as hardware gaskets, where alternative hardware to that tested is permitted in the following sections, Certifire approved hardware may be incorporated subject to the design, material and dimensional limitations identified within this assessment report and identified on the relevant Certifire certificate. This route cannot be used where only specific hardware options stated by the doorset manufacturer are permitted (i.e. where alternative hardware is not permitted).

14.3 Latches & Locks

Latches and locks must either be as tested, or alternatively components with the following specification are acceptable.

Maximum forend and strike plate dimensions	235mm high by 25mm wide by 4mm thick
Maximum body dimensions	18mm thick by 100mm wide by 165mm high
Intumescent protection	See section 11
Materials	All parts essential to the locking/latching action (including the latch bolt, forend and strike) to be steel or stainless steel
Position	1000mm to 1200mm from the threshold

14.4 Hinges

Door leaves must be hung on a minimum of 3 hinges. Leaves over 2135mm high must fit 4 hinges. Leaves over 2700mm high must fit 5 hinges. Hinges with the following specification are acceptable.

Element		Specification
Blade height		90 – 120mm
Blade width (excluding knuckle)		30 – 35mm
Blade thickness		2.5 – 4mm
Fixings		Minimum of 4 No. 30mm long No. 8 or No.10 coarsely threaded wood type, steel screws per blade
Materials		Steel or stainless steel
Hinge position	Leaf dimension <2135mm	Top - 150 -180mm from the head of leaf to top of the hinge
		2 nd - Minimum 200mm from top hinge or equispaced between top and bottom hinges
		Bottom - 180 – 250mm from the foot of the leaf to bottom of the hinge
	Leaf dimension ≥2135mm	Top - 150-180mm from the head of leaf to top of the hinge
		2 nd & 3 rd (leaves < 2700mm) - 2 nd hinge minimum 200mm from top hinge & 3 rd hinge equispaced between 2 nd and bottom hinge or both hinges equispaced between top and bottom hinge
		2 nd & 3 rd & 4 th (leaves > 2700mm) - Equispaced between top and bottom hinges
	Bottom - 180 – 250mm from the foot of leaf to bottom of the hinge	
Intumescent protection		See section 11

14.5 Automatic Closing

Automatic closing devices must either be as tested or components of equal specification that have demonstrated contribution to the required performance of these types of 60, 90 and 120 minute doorset designs, when tested to BS 476: Part 22: 1987 or BS EN 1634-1.

Notes:

1. The top pivots to floorspring assemblies must be protected with 2mm thick WSCP Strip-seal, or Interdens, on all edges of the mortise. The hardware manufacturer should be able to provide details on appropriate intumescent protection. Floor springs and pivots are only permitted for double acting door configurations and only for 60 minutes fire resistance;
2. Concealed overhead closers with fire test evidence for 60 minutes fire resistance in timber or mineral composite doors, to either BS 476: Part 22: 1987 or BS EN 1634-1, may be fitted to the design but for 60 minute fire resisting applications only. Specific test evidence for concealed closers must be generated for 90 and 120 minutes fire resisting applications.

14.6 Pull Handles

Steel or stainless steel pull handles may be surface-fixed or bolted through the door leaf provided that they are steel, the length is limited to 1000mm between fixing points, 1mm thick Interdens is wrapped around the full length of the stud and the hole through the leaf is tight to the stud.

14.7 Push Plates/Kick Plates/Generic Signage

Steel or stainless steel surface-fixed hardware such as push plates, kick plates and metal signage (hotel door numbers etc.) may be fitted to the doorsets provided that their fitting requires the removal of no part of the door leaf. These items of hardware must not amount to more than 20% of the door leaf area and must not return around the door edge.

14.8 Panic Hardware

Panic hardware may be fitted, provided that its installation does not require the removal of any timber or Tectonite from the leaf, stop or frame reveal and it does not interfere with the ability of the door leaf to self close fully into the frame reveal.

14.9 Signage

Plastic or metal fire safety signs may be glued or screwed to the face of the door leaves. The signage must comply with BS 5499-5: 2002 according to whether the door is:

1. To be kept closed when not in use (Fire Door Keep Shut);
2. To be kept locked shut when not in use (Fire Door Keep Locked Shut);
3. Held open by an automatic release mechanism or free swing device (Automatic Fire Door Keep Clear).

14.10 Air Transfer Grilles

Air transfer grilles may be fitted provided they have demonstrated contribution to the required performance of these types of 60, 90 and 120 minute doorset designs, when tested to BS 476: Part 22: 1987 or BS EN 1634-1, in a leaf of comparable thickness.

Margins to the leaf edges will remain as detailed for glazing and the position of the unit will be dictated by the pressure regime tested in the proving evidence (normally below mid height). The area occupied by the air transfer grille must not exceed 0.18m² and must be deducted from the area of glazing, if both elements are fitted.

If it is required to fit air transfer grilles outside the aforementioned scope, guidance and appropriate test evidence must be sought from the manufacturer of the grille, including permitted numbers of grilles, spacing within the door leaf, additional intumescent, aperture liners and location within the doorset (with respect to pressure regime).

15 Door Gaps

For fire resistance performance door gaps and alignment tolerances must fall within the following range.

Location	Dimensions
Door edge gaps	A minimum of 2mm and a maximum of 4mm
Alignment tolerances	Leaves must not be proud of each other or from the door frame by more than 1mm
Threshold	10mm between bottom of leaf and top of floor covering, see section 20 for smoke control performance

16 Structural Opening

The supporting construction must provide the required level of fire resistance designated for the doorset design and be a suitable medium to permit adequate fixity.

17 Fixings

The supporting construction must be capable of staying in place and intact for the full period of fire resistance required from the doorset. The frame jambs are to be fixed to the supporting construction using 5 No. steel fixings (1 fixing 200mm below the head and 1 fixing 200mm above the threshold with 3 No. fixings equally spaced between). Two fixings are required in the frame head, set a maximum of 500mm from the jambs. The fixings must be of the appropriate type for the supporting construction and must penetrate to a minimum depth of 50mm.

18 Sealing to Structural Opening

The door frame to structural opening gap must be protected using one of the following methods.

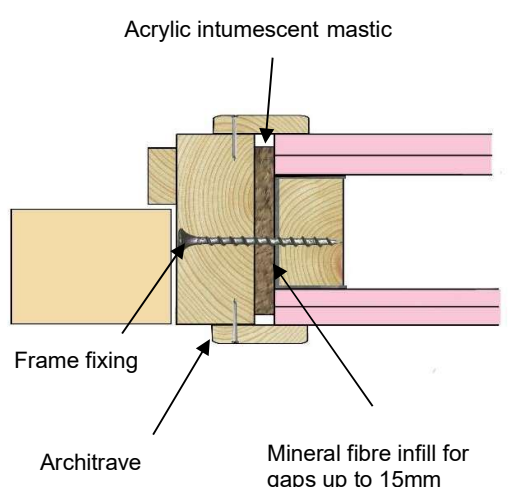
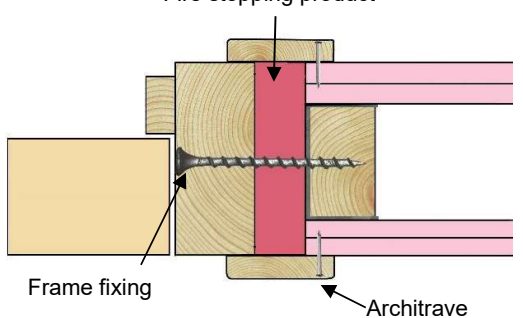
<p>1. Gaps up to 10mm must be sealed on both sides with a 20mm depth of acrylic intumescent mastic that has demonstrated 90 or 120 minutes integrity to BS 476: Part 22: 1987 or BS EN 1634-1 (between masonry and timber or mineral composite). Joint must be fitted with 18mm thick hardwood architraves overlapping at least 15mm each side.</p>	
<p>2. Gaps between 10 and 20mm must be tightly packed with mineral fibre and filled on both faces with a minimum of 20mm depth of intumescent mastic that has demonstrated 90 or 120 minutes integrity to BS 476: Part 22: 1987 or BS EN 1634-1 (between masonry and timber or mineral composite). The frame to structural opening gap must be covered with a minimum of 18mm thick hardwood architraves overlapping at least 15mm each side.</p>	

Further to the options above it is permitted to install the door without architraves (or with architraves that do not meet the 15mm overlap requirement) providing the gap between the frame and the structural opening is suitably sealed with a proven linear gap seal that meets the following provisos:

1. The sealing medium has been tested at the required thickness and depth and has demonstrated 60, 90 or 120 minutes integrity, as appropriate, to BS 476: Part 22: 1987 or BS EN 1634-1 (between masonry and timber or mineral composite);
2. The sealing medium was tested without architrave or any other capping material.

19 Insulation

The insulation performance for the WSCP doorset design is given below.

Details	Insulation Performance
Unglazed Doorsets	90 Minutes

20 Smoke Control

20.1 General

If the doorset design is required to provide a smoke control function to comply with Building Regulations, the doorset must meet one of the following criteria (unless pressurisation techniques complying with BS EN 1201-6 are used);

- a) have a leakage rate not exceeding $3\text{m}^3/\text{m}/\text{hour}$ (head and jambs only) when tested at 25Pa under BS 476 *Fire tests on building materials and structures*, Section 31.1 – *Methods for measuring smoke penetration through doorsets and shutter assemblies, Method of measurement under ambient temperature conditions*; or
- b) meet the additional classification requirement of Sa when tested to BS EN 1634-3:2004 – *Fire resistance tests for door and shutter assemblies*, Part 3 – *Smoke control doors*.

Smoke seals or combined intumescent/smoke seals that are fitted to the door to achieve the performance requirements specified above, must have been tested in accordance with the associated test method. Providing the smoke seals, any interruptions, door gaps, and the type/configuration of the doorset are consistent with the detail tested, the doorset will comply with current smoke control legislation under approved document B; and a suffix 'S' or 'Sa', as appropriate, may be added to the designation. Any other components installed where smoke leakage may occur must also be taken into account.

Note: The incorrect specification and fitting of smoke seals may impair the operation of a doorset and therefore compromise the fire resistance performance. Advice should be sought from the seal manufacturers regarding the correct specification and installation of smoke seals or combined smoke and intumescent seals.

20.2 Further Considerations

Other guidance is available, including BS EN 9999-2017 - *Code of practice for fire safety in the design, management and use of buildings*, which may impose different or additional requirements. It is the responsibility of the relevant parties to agree the precise smoke control specification, prior to commencing manufacture and/or installation.

21 Conclusion

If the WSCP doorset designs, constructed in accordance with the specification documented in this global assessment, were to be tested in accordance with BS 476: Part 22: 1987, it is our opinion that they would provide a minimum of 60, 90 and 120 minutes integrity, as appropriate.

22 Declaration by the Applicant

1. We the undersigned confirm that we have read and comply with obligations placed on us by FTSG Resolution No 82: 2001.
2. We confirm that the component or element of structure, which is the subject of this assessment, has not to our knowledge been subjected to a fire test to the Standard against which this assessment is being made.
3. We agree to withdraw this assessment from circulation should the component or element of structure be the subject of a fire test to the Standard against which this assessment is being made.
4. We are not aware of any information that could adversely affect the conclusions of this assessment.
5. If we subsequently become aware of any such information we agree to ask the assessing authority to withdraw the assessment.

Signed: 

Name: **Jacob S Coochise**

For and on behalf of: Warn Springs Composite Products Ltd.



23 Limitations

The following limitations apply to this assessment:

1. This assessment addresses itself solely to the elements and subjects discussed and does not cover any other criteria. All other details not specifically referred to should remain as tested or assessed.
2. This assessment is issued on the basis of test data and information to hand at the time of issue. If contradictory evidence becomes available, Warringtonfire reserves the right to withdraw the assessment unconditionally but not retrospectively.
3. This assessment has been carried out in accordance with Fire Test Study Group Resolution No 82: 2001.
4. Opinions and interpretations expressed herein are outside the scope of UKAS accreditation.
5. This assessment relates only to those aspects of design, materials and construction that influence the performance of the element(s) under fire resistance test conditions. It does not purport to be a complete specification ensuring fitness for purpose and long-term serviceability. It is the responsibility of the client to ensure that the element conforms to recognised good practice in all other respects and that, with the incorporation of the guidance given in this assessment, the element is suitable for its intended purpose.
6. This assessment represents our opinion as to the performance likely to be demonstrated on a test in accordance with BS476: Part22: 1987, on the basis of the evidence referred to in appendix A. We express no opinion as to whether that evidence, and/or this assessment, would be regarded by any Building Control authority as sufficient for that or any other purpose. This assessment is provided to the client for its own purposes and we cannot opine on whether it will be accepted by Building Control authorities or any other third parties for any purpose.
7. This report may only be reproduced in full. Extracts or abridgements of reports shall not be published without permission of Warringtonfire. All work and services carried out by Warringtonfire Testing and Certification Limited are subject to, and conducted in accordance with, the Standard Terms and Conditions of Warringtonfire Testing and Certification Limited, which are available at <https://www.element.com/terms/terms-and-conditions> or upon request.
8. The version/revision stated on the front of this Field of Application supersedes all previous versions/revisions and must be used to manufacture doorsets from the stated validity date on this front cover. Previous revisions of the Field of Application cannot be used once an updated Field of Application has been issued under a new revision.

24 Validity

1. The assessment is initially valid for 1 year after which time it must be submitted to Warringtonfire for technical review and revalidation.
2. This assessment report is not valid unless it incorporates the declaration given in Section 22 duly signed by the applicant.

Signature:		
Name:	Liam Dunk	Kevin Towler
Title:	Product Assessor	Senior Product Assessor

Appendix A Performance Data

Primary Data

Report No.	Configuration	Leaf Size (mm)	Test Standard	Performance (mins)
RF03070 (Intumescent Option 1)	ULSADD	2100 900 55	BS 476: Part 22: 1987	122 (integrity) ¹ 110 (insulation)
CFR1007071 (Intumescent Option 2)	LSADD	2265 1050 57	BS 476: Part 22: 1987	116 (integrity) 95 (insulation)
CFR1007081 (Intumescent Option 2)	LSASD	2340 1075 57	BS 476: Part 22: 1987	Right hand specimen 91 (integrity) 84 (insulation) Left hand specimen 105 (integrity) 93 (insulation)
CFR1009081 (Intumescent Option 2)	LSADD	2236 1036 57	BS 476: Part 22: 1987	131 (integrity) 90 (insulation)
CFR1103111 (Intumescent Option 2)	ULSADD	2292 1068 57	BS 476: Part 22: 1987	151 (integrity) 98 (insulation)

Notes:

- The tested specimen failed under the integrity criterion at 122 and 127 minutes due to continuous flaming from hinge positions. The specimen continued until 132 minutes at which time the facing ignited. Assessment has been made to use the later failure of 132 minutes integrity, as the basis of leaf size calculations, by increasing the quantity of intumescent hinge protection by 100%, from 1mm thick Interdens to 2mm.
- An alternative intumescent detail for Option 2 has been assessed from that tested by specifying 2 No. 22 x 4mm seals at the perimeter and meeting edges instead of 2 No. 20 x 4mm seals at the meeting edges and 1No. 25 x 4mm and 1 No. 20 x 4mm around the perimeter. It is Warringtonfire's opinion that the alteration in intumescent specification is unlikely to significantly affect the tested performances, based on the stability of the design and the over-run in performance achieved. However, to compensate for the marginal reduction of material around the perimeter of the leaf (approximately 2.5% less intumescent by volume), the assessed leaf sizes given in appendix E have been reduced by 2.5%. The altered intumescent specification is provided in section 11.2 and the original specification is given in section 11.3. The associated data sheets are given in appendix E.

Supporting Data

Report No.	Configuration	Leaf Size (mm)	Test Standard	Performance (mins)
WF63295 (Glazing evidence)	ULSADD	2040 826 44	BS 476: Part 22: 1987	149 (integrity) 70 (insulation)
WHI 495 PSV 1553 (multi piece stiles and rails)	Fixed sample	900 1000 44	UBC Standard 7- 2 (1997)	90 (integrity) with 28 second hose stream test
UL – 100359573COQ- 009 (Removal of intumescent gasket requirement around lock body for 60 and 90 minute applications)	LSASD	2440 1220 44	UL 10(c) (2009) and CAN/ULCS 104 – 10	90 (integrity) with 48 second hose stream
IF12047 (Norglaze Universal 90)	ULSASD sample	1040 996 58	Principles of BS 476: Part 20: 1987	106 (integrity)
CFR1806192 Revision 1 (Pyrodur test evidence)	Fixed sample	2038 (h) 527 55	Principles of BS 476: Part 22: 1987	132 (integrity)

Appendix B Assessed Glazing System

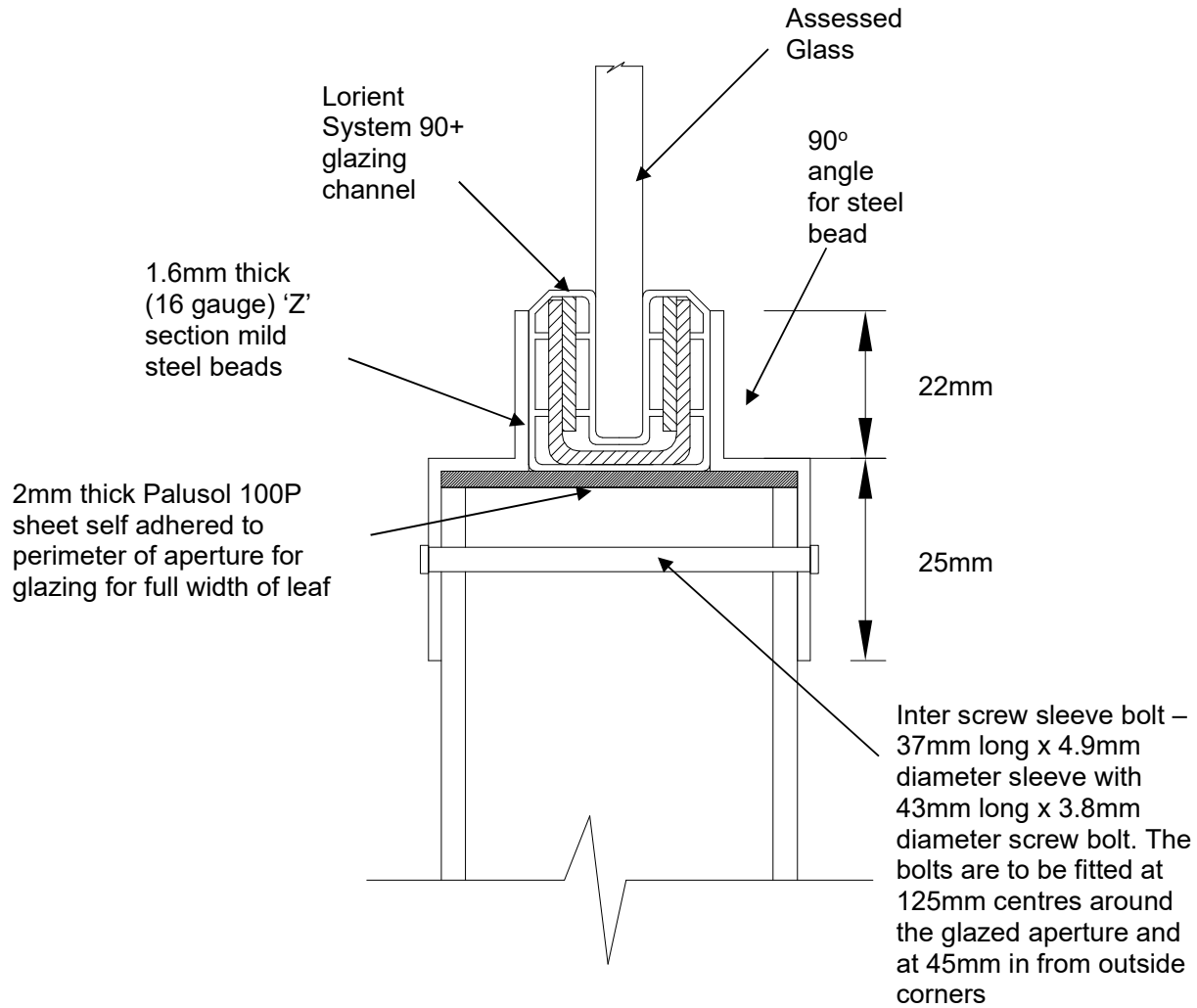

Appendix C Tectonite Door Frame Constructions

Tectonite (2 - 4mm hardwood or MDF veneer)

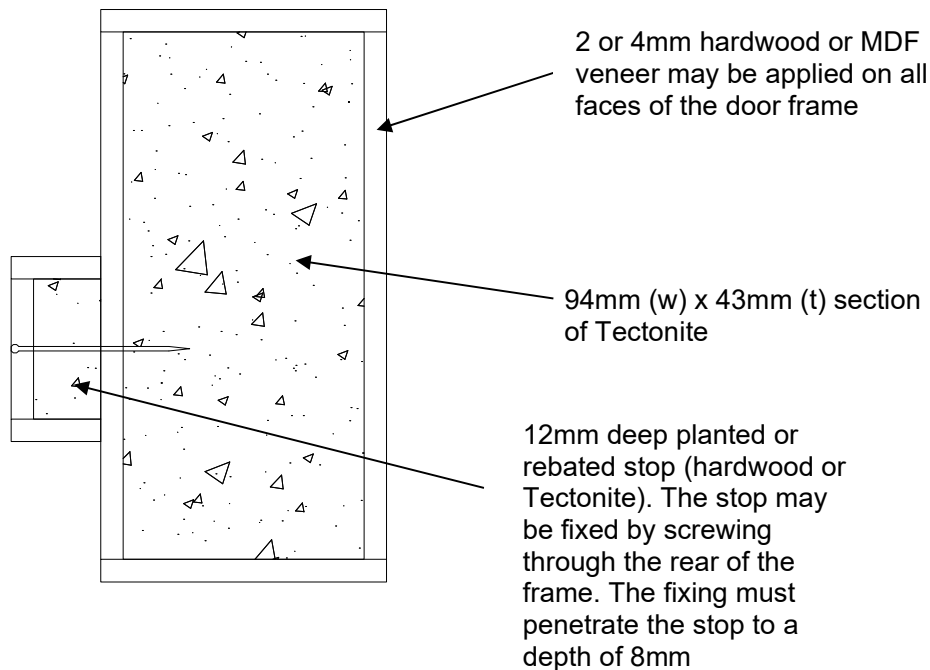

Tectonite (hardwood composite)

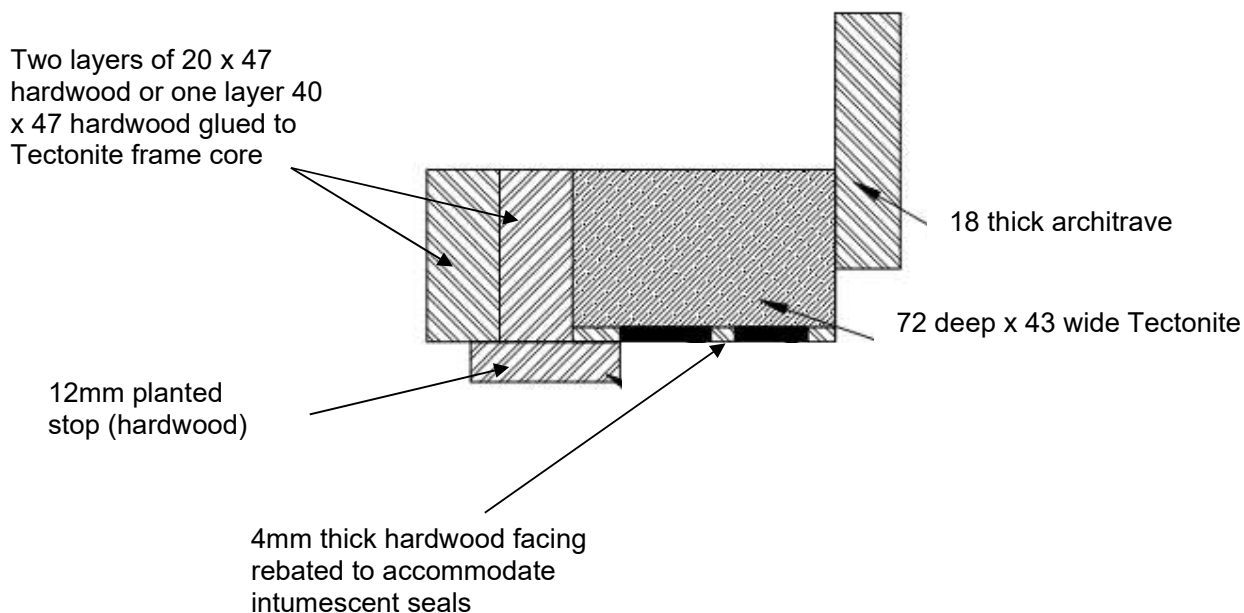

Warm Springs Composite Products T-Stop detail (measurements in mm)

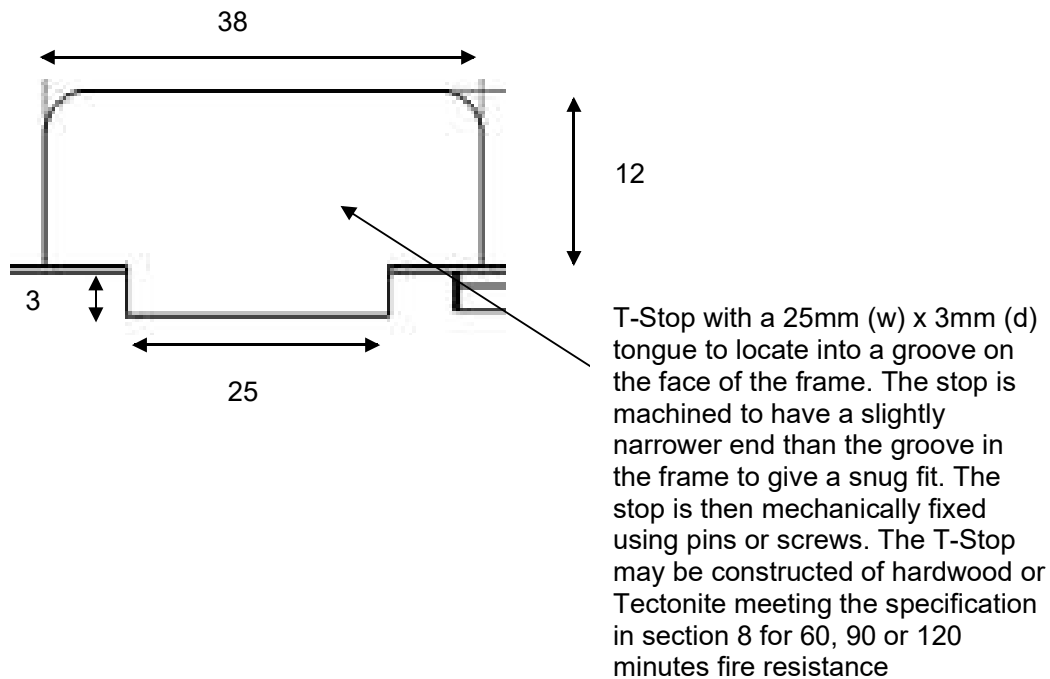

Warm Springs Composite Products frame width extension detail

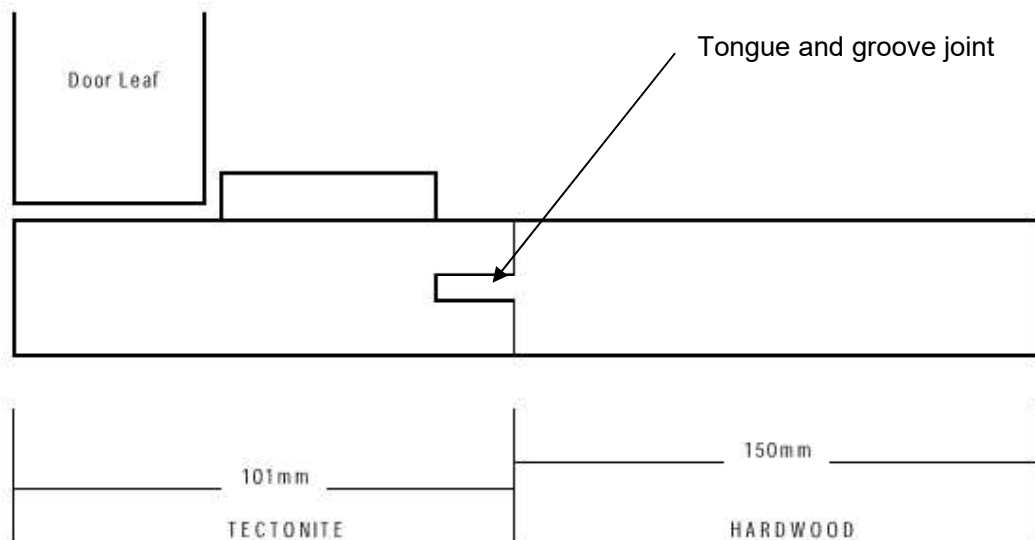

Appendix D Revisions

Revision	Warringtonfire Reference	Date	Description
A	Chilt/A10229	31/01/11	Technical review, update of assessment format and revalidation for a further 5 years including test data CFR1007071, CFR1007081 and CFR1009081.
B	Chilt/A11145	18/07/11	Inclusion of test data CFR1103111 to rationalise the design options, allow for variable stile and rail widths, permit hotmelt adhesive for lipping door edges at all ratings and allow for additional leaf sizes at 60, 90 and 120 minutes in latched and unlatched configurations.
C	Chilt/A12092	11/05/12	Removal of intumescent gasket requirement around the lock body for 60 and 90 minute applications (Design A and Design B) based on UL test evidence referenced 100359573COQ-009; concealed over head closers for 60 minute applications; air transfer grilles; increase in decorative groove scope to allow for different grooving patterns - limitation to be presented as a percentage of material removal from the outer face; alteration to construction to allow for enhanced acoustic performance; to include: 6mm MDF outer faces (all leaf dimensions permitted at 60 and 90 minutes fire resistance, 2292mm (h) x 1068mm (w) at 120 minutes fire resistance); NOR810s drop seal; NOR710 around perimeter of leaf; adjustment to leaf edge – stiles 25mm to 43mm, rails 51mm to 102mm (Design B only, all ratings); architrave and sealing to structural opening options (option for no architrave subject to suitably tested linear gap seal); door frame options – minimum section of Tectonite to be stated as 94mm (w) x 43mm (t) to allow for sizing during manufacture; veneer options for door frame to include hardwood and MDF; inclusion of drilling pilot holes in Tectonite for frame construction and fitting of hardware; repositioning the second hinge to within 100mm of the top hinge; inclusion of Norglaze Universal 90 glazing system.
D	Chilt/A12092	03/08/12	Inclusion of metal signage, additional intumescent specification for WSCP Design B and alternative planted stop material.
E	CNA/F15171	16/10/15	Inclusion of test data from RF12178, CFR1504141 & CFR1410311 covering hardwood door frames up to 120 minutes, a range of Hoppe UK Ltd, Zoo Architectural Hardware Ltd, Turentek Architectural Hardware Ltd. & Cooke Brothers Ltd. hardware; removal of all references to Door Design A and removal of option 2 from the intumescent options for the remaining doorset design.
F	WF435276	19/11/20	Technical review and revalidation for a further 1 year, modifying scope to be inline with assessment Chilt/A12138 Rev A.

Appendix E

Datasheets for:

Warm Springs Composite Product Doorsets for:

Falcon Panel Products Ltd.

All envelops have been generated using test report CFR1103111

60 Minutes Fire Resistance

Latched and Unlatched Single and Double Acting Single Doorsets

	Configuration		Height (mm)		Width (mm)
Leaf Sizes	LSASD	From:	2292	x	1635
		To:	3498	x	1068
	ULSASD & DASD	From:	2292	x	1610
		To:	3448	x	1068
Maximum Overpanel Height (mm)	Transomed		500		
Intumescent Materials: WSCP Intumescent Option 1					
Head: See section 11.1					
Jambs: See section 11.1					
Hardware Protection: See section 11.1					

Maximum Door Leaf Size

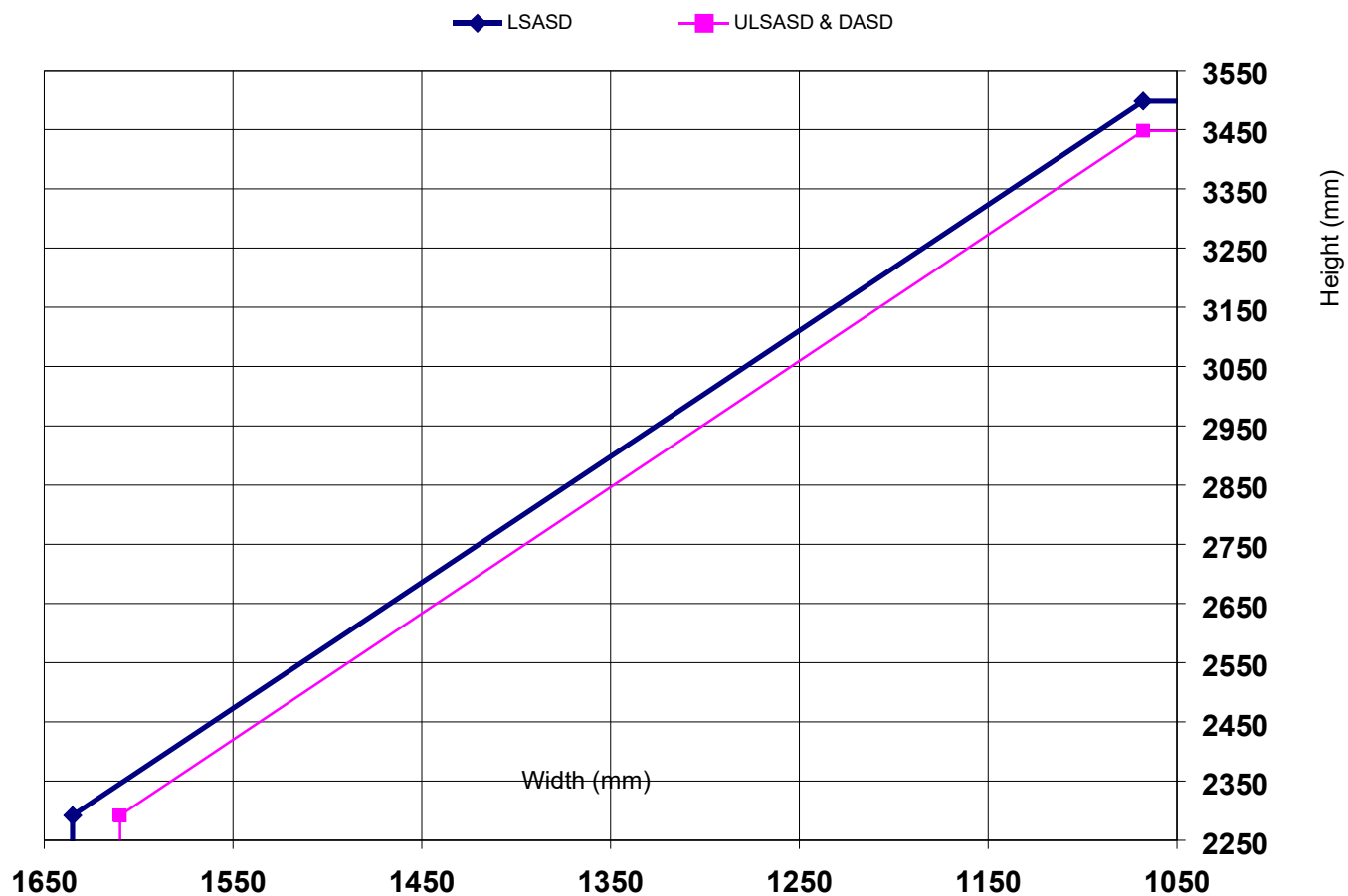

60 Minutes Fire Resistance

Latched and Unlatched Single and Double Acting Double Doorsets

	Configuration		Height (mm)		Width (mm)
Leaf Sizes	LSADD	From:	2292	x	1585
		To:	3398	x	1068
	ULSADD & DADD	From:	2292	x	1560
		To:	3348	x	1068
Maximum Overpanel Height (mm)	Transomed	500			
Intumescent Materials: WSCP Intumescent Option 1					
Head: See section 11.2					
Jambs: See section 11.2					
Hardware Protection: See section 11.2					

Maximum Door Leaf Size

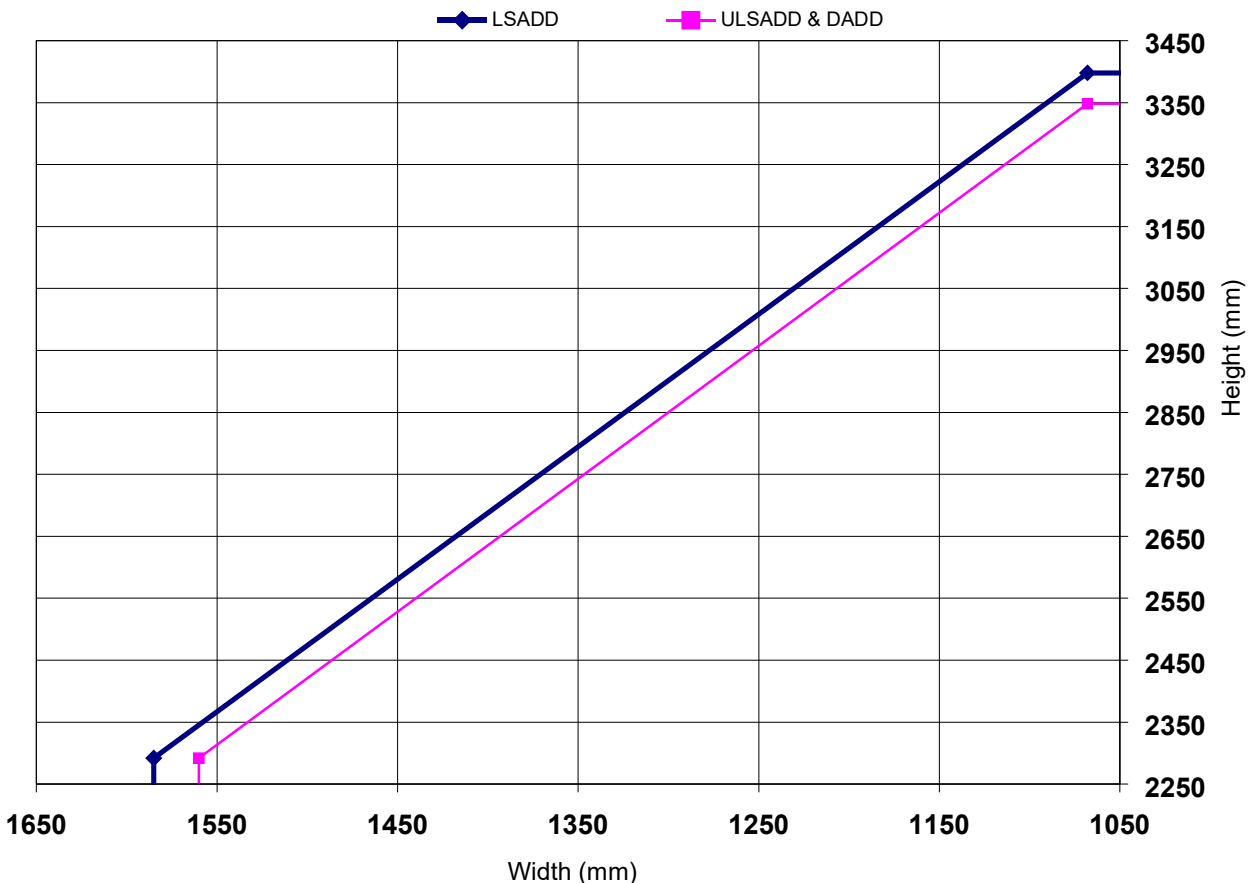

90 Minutes Fire Resistance

Latched and Unlatched Single Acting Single Doorsets

	Configuration		Height (mm)		Width (mm)
Leaf Sizes	LSASD	From:	2292	x	1462
		To:	3129	x	1068
	ULSASD	From:	2292	x	1437
		To:	3079	x	1068
Maximum Overpanel Height (mm)		Transomed	500		
Intumescent Materials: WSCP Intumescent Option 1					
Head: See section 11.2					
Jamb: See section 11.2					
Hardware Protection: See section 11.2					

Maximum Door Leaf Size

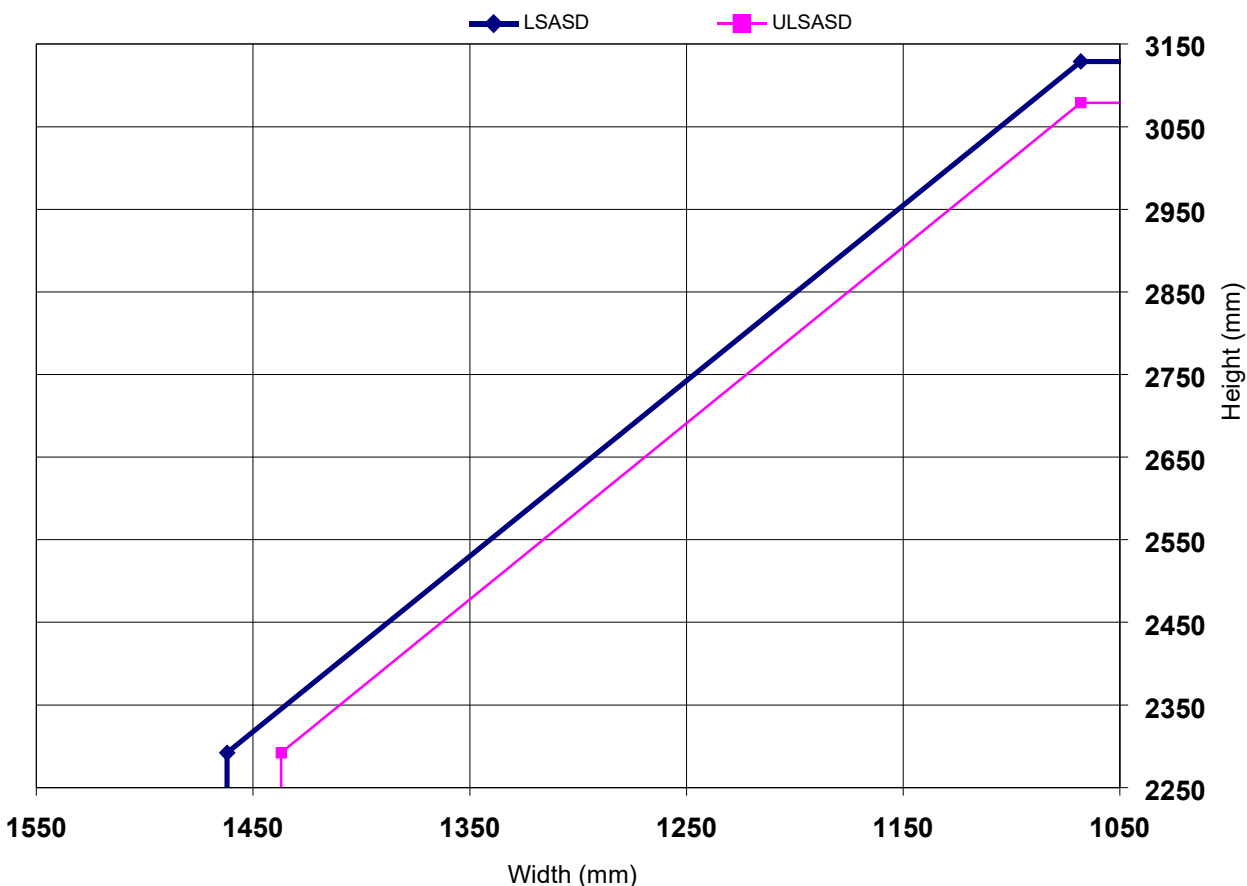

90 Minutes Fire Resistance

Latched and Unlatched Single Acting Double Doorsets

	Configuration		Height (mm)		Width (mm)
Leaf Sizes	LSADD	From:	2292	x	1412
		To:	3029	x	1068
	ULSADD	From:	2292	x	1387
		To:	2979	x	1068
Maximum Overpanel Height (mm)	Transomed	500			
Intumescent Materials: WSCP Intumescent Option 1					
Head: See section 11.2					
Jambs: See section 11.2					
Hardware Protection: See section 11.2					

Maximum Door Leaf Size

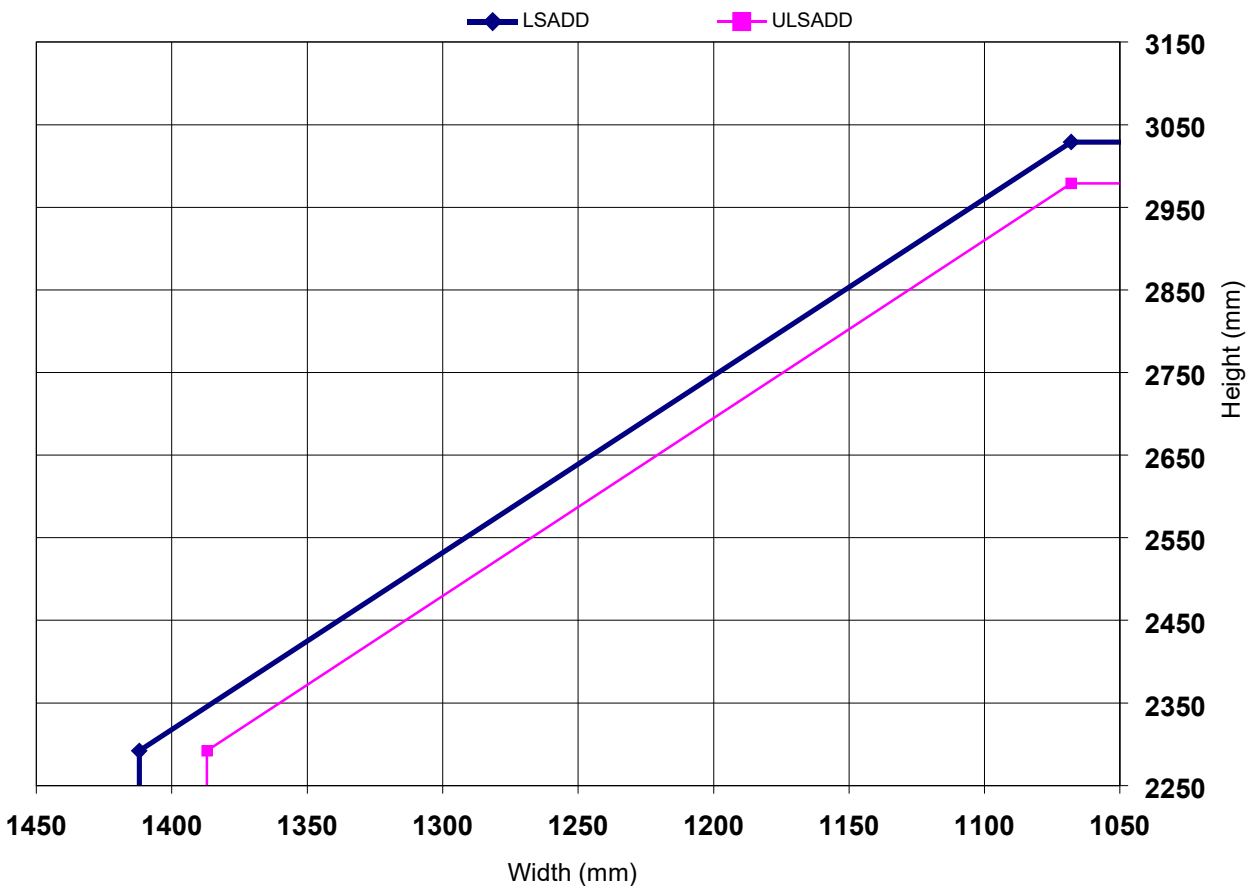

120 Minutes Fire Resistance

Latched and Unlatched Single Acting Single Doorsets

	Configuration		Height (mm)	Width (mm)
Leaf Sizes	LSASD	From:	2292	x 1203
		To:	2571	x 1068
	ULSASD	From:	2292	x 1178
		To:	2521	x 1068
Maximum Overpanel Height (mm)		Transomed	500	
Intumescent Materials: WSCP Intumescent Option 1 Head: See section 11.2 Jambs: See section 11.2 Hardware Protection: See section 11.2				

Maximum Door Leaf Size

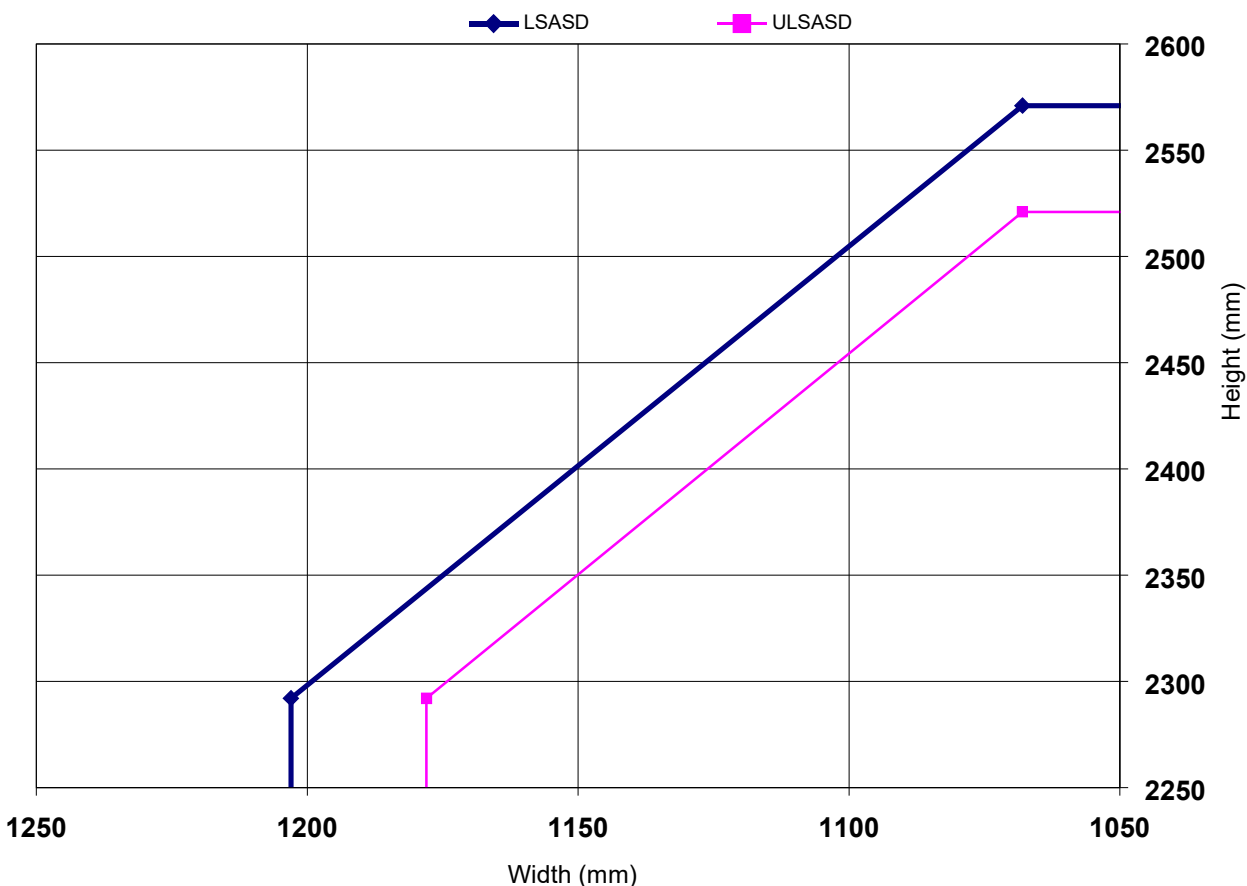

120 Minutes Fire Resistance

Latched and Unlatched Single Acting Double Doorsets

	Configuration		Height (mm)		Width (mm)
Leaf Sizes	LSADD	From:	2292	x	1153
		To:	2471	x	1068
	ULSADD	From:	2292	x	1128
		To:	2421	x	1068
Maximum Overpanel Height (mm)		Transomed	500		
Intumescent Materials: WSCP Intumescent Option 1					
Head: See section 11.2					
Jams: See section 11.2					
Hardware Protection: See section 11.2					

Maximum Door Leaf Size

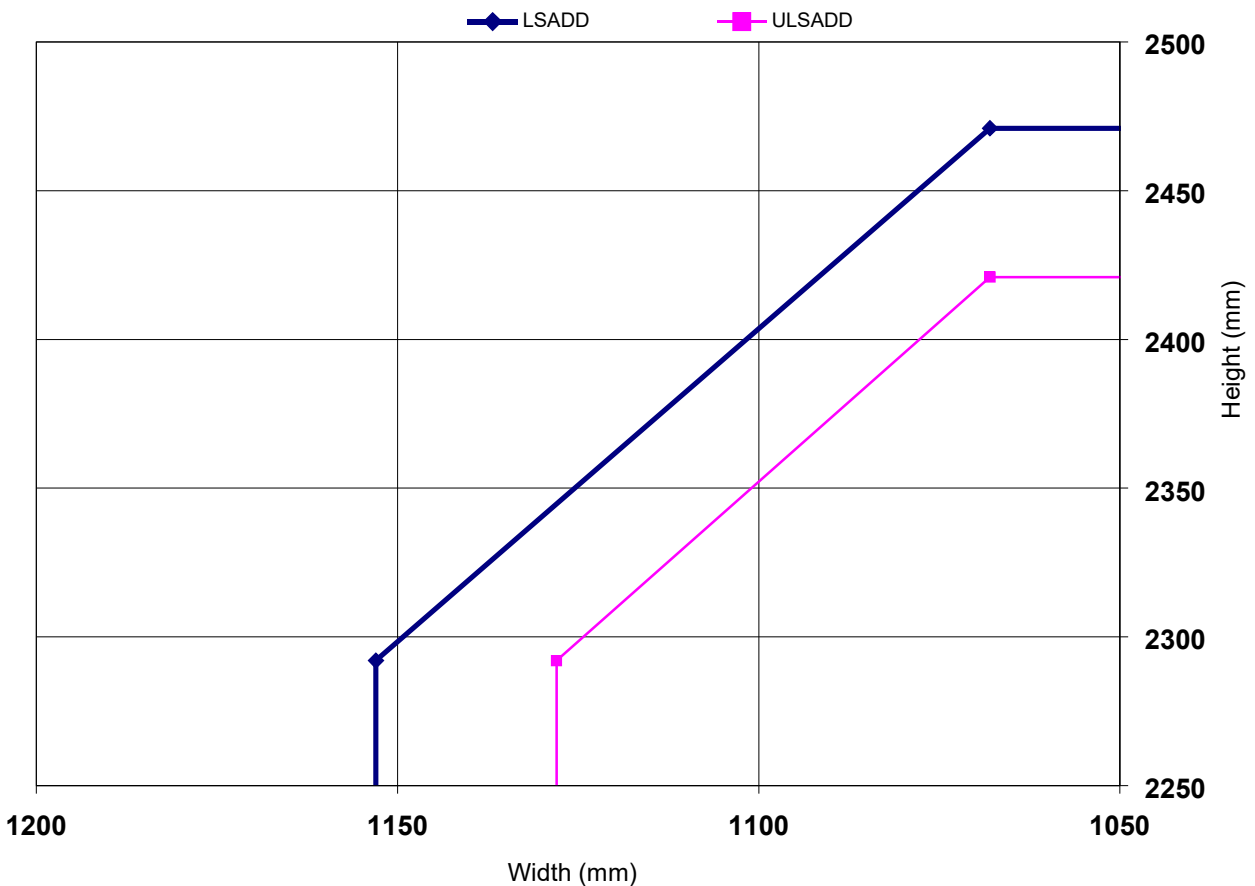

60 Minutes Fire Resistance

Latched and Unlatched Single and Double Acting Single Doorsets

	Configuration		Height (mm)		Width (mm)
Leaf Sizes	LSASD	From:	2292	x	1677
		To:	3588	x	1068
	ULSASD & DASD	From:	2292	x	1652
		To:	3538	x	1068
Maximum Overpanel Height (mm)		Transomed	500		
Intumescent Materials: WSCP Intumescent Option 2 Head: See section 11.3 Jambs: See section 11.3 Hardware Protection: See section 11.3					

Maximum Door Leaf Size

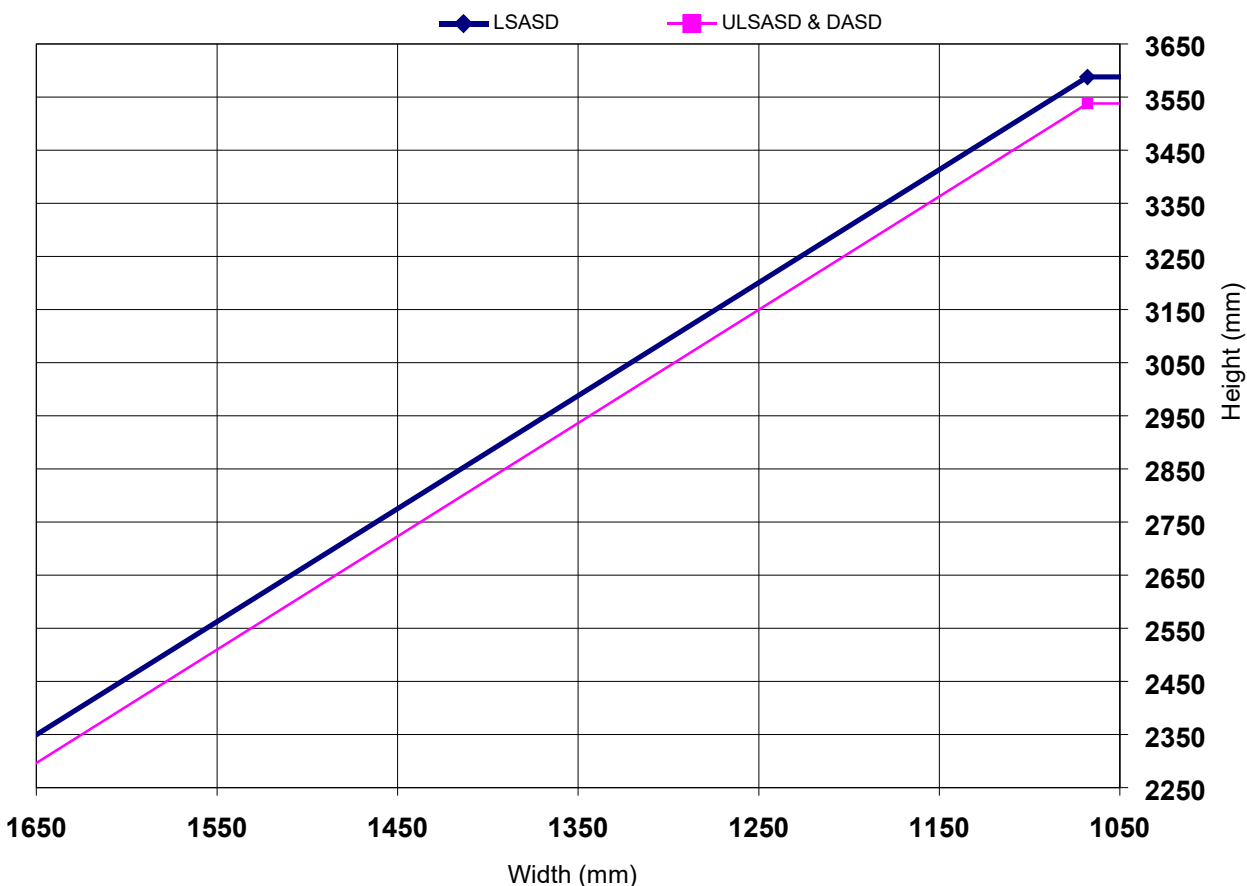

60 Minutes Fire Resistance

Latched and Unlatched Single and Double Acting Double Doorsets

	Configuration		Height (mm)		Width (mm)
Leaf Sizes	LSADD	From:	2292	x	1627
		To:	3488	x	1068
	ULSADD & DADD	From:	2292	x	1602
		To:	3438	x	1068
Maximum Overpanel Height (mm)		Transomed	500		
Intumescent Materials: WSCP Intumescent Option 2 Head: See section 11.3 Jambs: See section 11.3 Hardware Protection: See section 11.3					

Maximum Door Leaf Size

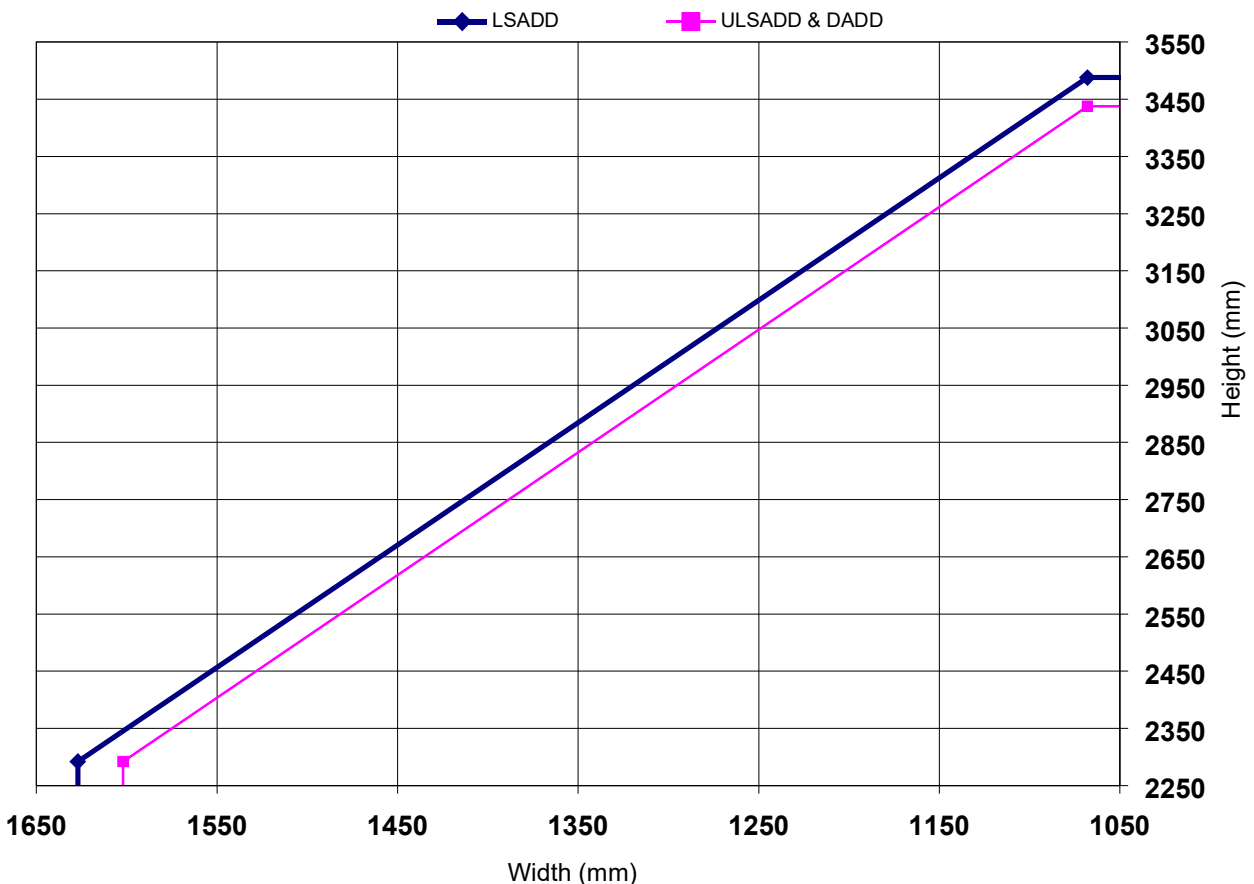

90 Minutes Fire Resistance

Latched and Unlatched Single Acting Single Doorsets

	Configuration		Height (mm)	Width (mm)
Leaf Sizes	LSASD	From:	2292	x 1500
		To:	3209	x 1068
	ULSASD	From:	2292	x 1475
		To:	3159	x 1068
Maximum Overpanel Height (mm)	Transomed	500		
Intumescent Materials: WSCP Intumescent Option 2				
Head: See section 11.3				
Jambs: See section 11.3				
Hardware Protection: See section 11.3				

Maximum Door Leaf Size

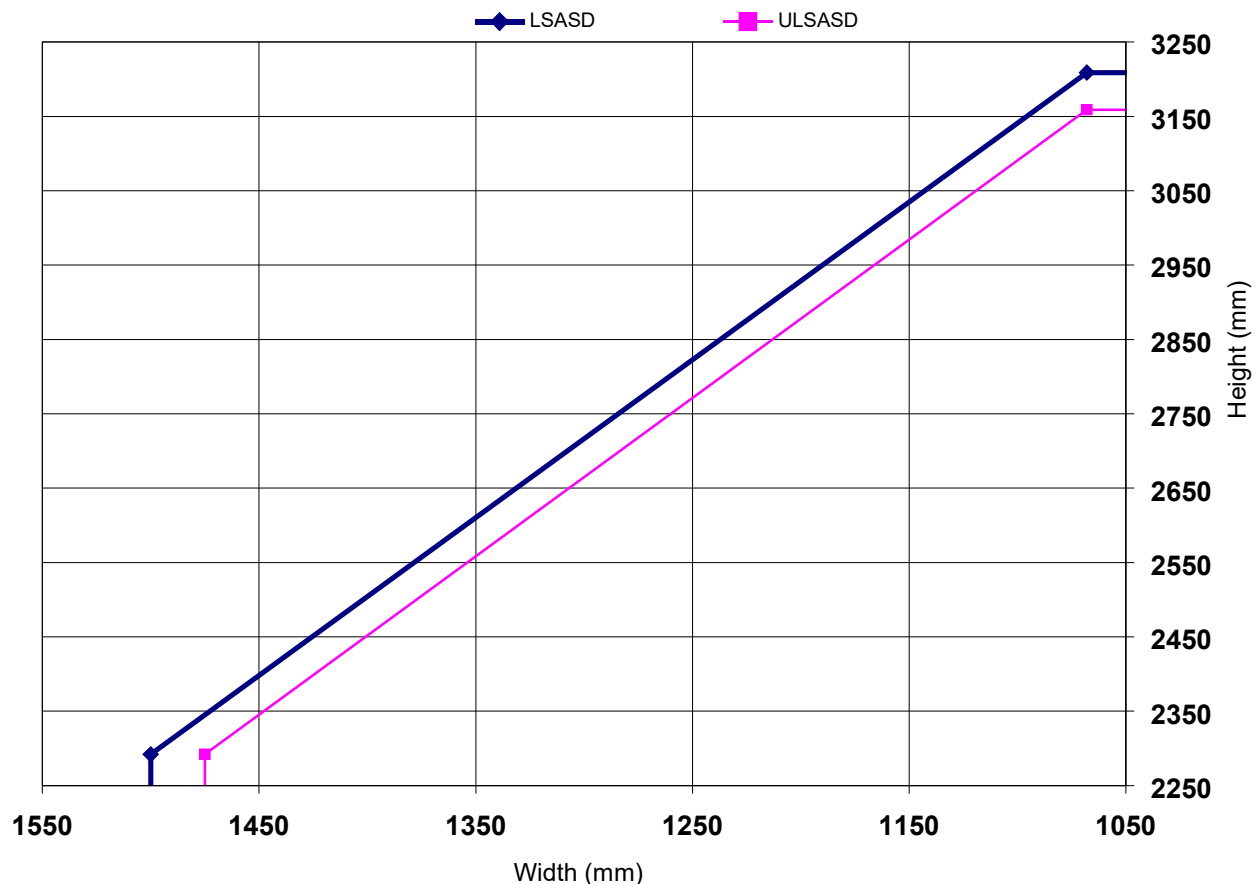

90 Minutes Fire Resistance

Latched and Unlatched Single Acting Double Doorsets

	Configuration		Height (mm)		Width (mm)
Leaf Sizes	LSADD	From:	2292	x	1450
		To:	3109	x	1068
	ULSADD	From:	2292	x	1425
		To:	3059	x	1068
Maximum Overpanel Height (mm)		Transomed	500		
Intumescent Materials: WSCP Intumescent Option 2					
Head: See section 11.3					
Jambs: See section 11.3					
Hardware Protection: See section 11.3					

Maximum Door Leaf Size

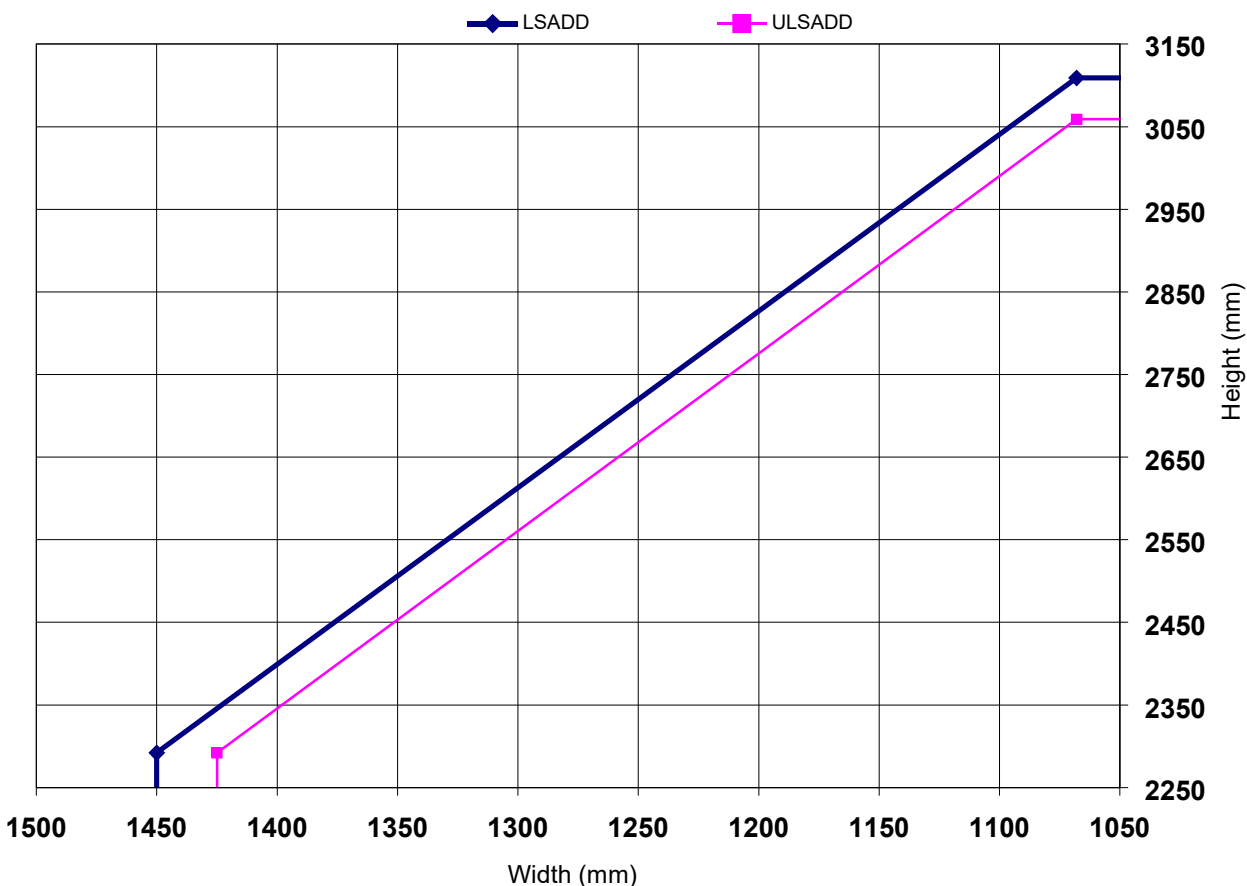

120 Minutes Fire Resistance

Latched and Unlatched Single Acting Single Doorsets

	Configuration		Height (mm)		Width (mm)
Leaf Sizes	LSASD	From:	2292	x	1234
		To:	2637	x	1068
	ULSASD	From:	2292	x	1209
		To:	2587	x	1068
Maximum Overpanel Height (mm)		Transomed	500		
Intumescent Materials: WSCP Intumescent Option 2 Head: See section 11.3 Jambs: See section 11.3 Hardware Protection: See section 11.3					

Maximum Door Leaf Size

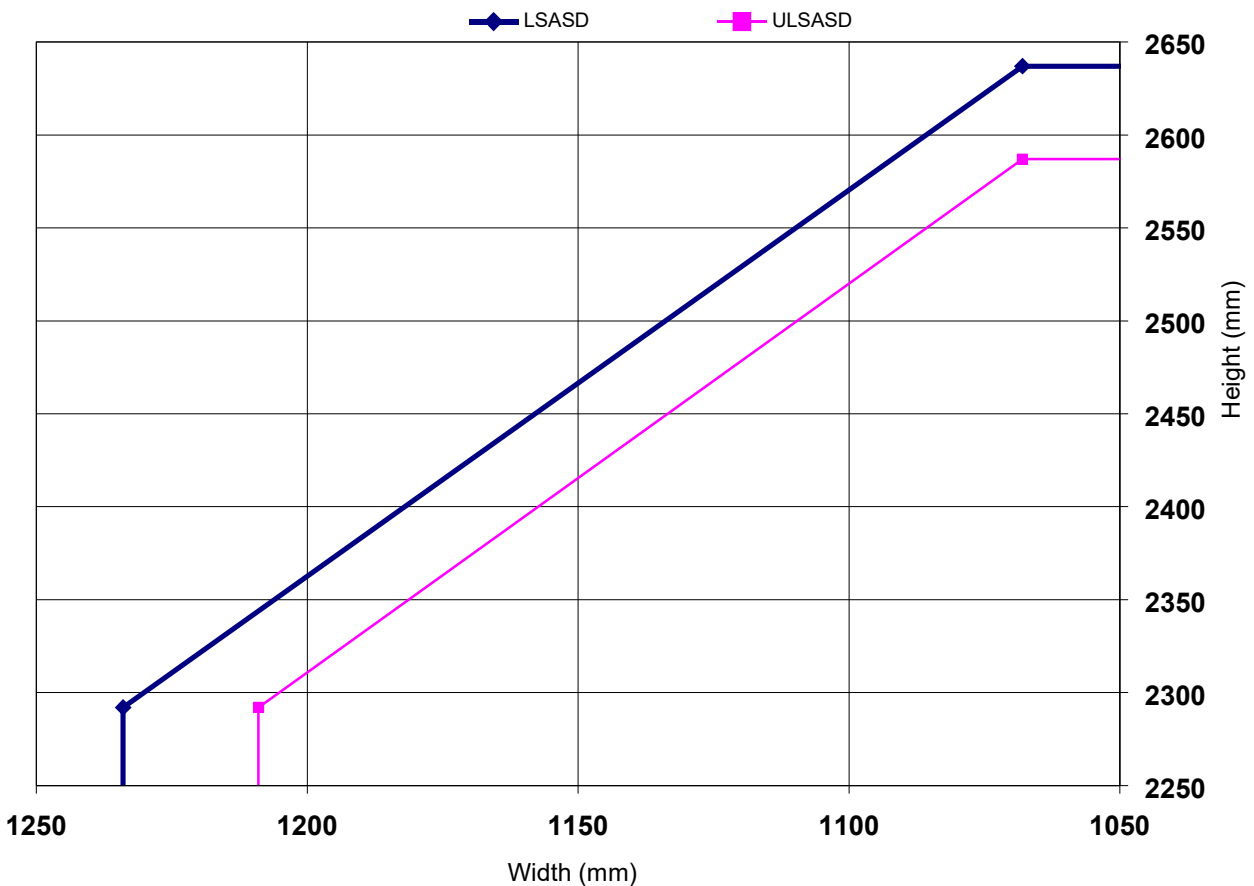

120 Minutes Fire Resistance

Latched and Unlatched Single Acting Double Doorsets

	Configuration		Height (mm)		Width (mm)
Leaf Sizes	LSADD	From:	2292	x	1184
		To:	2537	x	1068
	ULSADD	From:	2292	x	1159
		To:	2487	x	1068
Maximum Overpanel Height (mm)		Transomed	500		
Intumescent Materials: WSCP Intumescent Option 2 Head: See section 11.3 Jambs: See section 11.3 Hardware Protection: See section 11.3					

Maximum Door Leaf Size

